

# **WHIP INDUSTRIES, INC.**

**WFP15ARO**

**&**

**WFP15ARO-E**

**15,000 LBS CAPACITY**

**FOUR POST GROUND ALIGNMENT LIFT**

**INSTALLATION INSTRUCTIONS & MANUAL**

**WHIP INDUSTRIES, INC**

3010 S MAIN ST.

FORT WORTH, TEXAS 76110

PH (800) 256-7391 FAX (817) 289-1412

E-MAIL: [WhipInd@whipindustries.com](mailto:WhipInd@whipindustries.com)

REV. E

# **TABLE OF CONTENTS**

Important Information	3
Cautions and Warnings	3
Tools Required	4
Anchoring Tips	5
Installation Instructions	6
30 Day Maintenance	9
Trouble Shooting Guide	10
Parts & Shipping List	11
Parts Breakdown and Installation Drawings	15

## **IMPORTANT INFORMATION**

1. The floor where the lift is to be installed must be a minimum of 4” thickness of concrete. Concrete must be reinforced with steel rebar with a minimum compressive strength of 3,000 psi . Failure by the purchaser to provide the recommended mounting surfaces could result in personal injury, property damage and/or unsatisfactory lift performance.
2. Read the installation manual before installing the lift.
3. This lift is a four post alignment lift which requires a minimum Std. (15’-0” x 26’-0”) & Ext. (15’-0” x 27’-8”) bay area.
4. Read anchoring tips information before drilling and installing the anchor bolts.
5. Do not raise a vehicle with the lift until the lift has been correctly installed and adjusted as described in this manual.
6. Maximum floor variation between any two posts is 2 inches.

## **CAUTIONS AND WARNINGS**

**MOTORS AND ELECTRIC CONTROLS ARE NOT – SEALED AGAINST WEATHER OR MOISTURE. DAMAGE OR ELECTRICAL SHOCK MAY OCCUR IF INSTALLED UNPROTECTED OUTDOORS.**

**FACTORY MUST BE NOTIFIED WITHIN 30 DAYS OF DELIVERY IF THERE ARE ANY PARTS MISSING FROM SHIPMENT.**

**RECOMMENDED OIL: HYDRUALIC MEDIUM OIL SAE-10 OR EQUIVALENT. MAY USE TRANSMISSION FLUID DEXRON II OR III ATF.**

**ALL BOLTS PLACED IN THE COLUMN MUST BE PLACED FROM THE OUTSIDE FACING INWARD. UNLESS NOTED IN THE INSTALLATON INSTRUCTIONS.**

## **TOOLS REQUIRED**

Concrete rotary hammer drill with 3/4" carbide bit

Open End Wrenches: 7/16", 1/2", 3/4", & 1 1/8"

Ratchet Driver

Sockets: 1/2", 3/4" X 1/2" deep

12" Crescent Wrench

3/16 Allen Wrench

Phillips & Flat Head Screwdriver

Hammer

Needle Nose Pliers

Retainer Ring Pliers

Electrical Pliers

Level

Fish Tape

25' Tape Measure

Chalk Line

Small Drift Punch

Step Ladder

3 gallons of hydraulic medium oil SAE-10 or Dexron II or III ATF.

1 1/2 to 2 1/2 Gallons of Grout (Masterflow 928, Wedjrok Ready Mix Grout or Equivalent)

## ANCHORING TIPS

1. Anchor must be at least 5" from the edge of the slab or any seam.
2. Use a concrete hammer drill with a 3/4" carbide bit.
3. Do not use a worn bit.
4. Drill in a perpendicular line with the hole.
5. Do not apply excessive pressure to the drill. Let the drill do the work.
6. Lift the drill up and down occasionally to remove residue and to reduce binding.
7. Drill the hole depth equal to the length of the anchor, or completely through the slab.
8. For better holding power, blow all dust and residue from the hole before driving anchor into hole.

Place a flat washer over threaded end of anchor. Spin nut 1/2" down past end of anchor. Carefully tap anchor into the concrete until nut and flat washer are against base plate. Do not use an impact wrench to tighten.

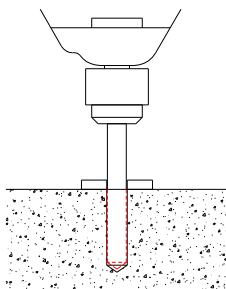

FIG. #1

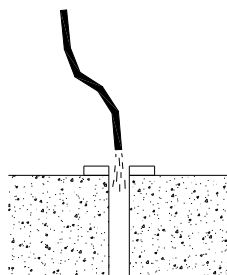

FIG. #2

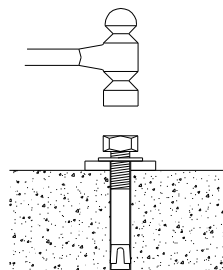

FIG. #3

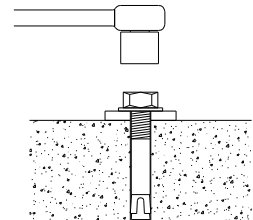

FIG. #4

## INSTALLATION INSTRUCTIONS

- 1) Area required for four post alignment lift is a minimum of Std. (15' x 26') or Ext. (15' x 27'-8") area.
- 2) Using the chalk line layout a rectangle (Std.) 15'-9" x 11'-9 3/8" or (Ext.) 17'-5" x 11'-9 3/8" at least 3'-7 3/8" from the ramp location and 1'-7 3/8" from either side of the lift (see Layout & Installation Specification sheet). This should give the lift 4" clearance in front of the ramps and 1'-7 3/8" from the side of the any leg.
- 3) Unpacking lift, inspect lift for any damages due to transportation and check shipping list for missing parts.
- 4) Locate the both Mainside Legs (see Fig. #2). Position legs as shown in the Installation Specification sheet for recommended installation. Optional - Mainside legs can be mounted on opposite side of lift depending on customer preference Hold the 14'-8" dimension of the legs center to center.
- 5) After measuring, Step #1 (see Fig. #5A) is to drill holes using a 3/4" diameter carbide drill bit. Keep in mind the anchoring tips mentioned previously in the manual. After drilling all 8 hole on the Mainside Legs, anchor them down with 3/4-10UNC 5 1/2 anchor bolts (8 pcs. - 91578A501). Make sure legs are level and plumb. Use 1/2-13UNC x 2 all threaded HHCS (4 pcs. - 92865A720) with 1/2-13UNC reg. hex nuts (4 pcs. - 90473A223) at the base plate to level legs. Make sure all bolts are properly set and meet 75 ft. lbs of torque. **DO NOT USE AN IMPACT.**
- 6) Locate Top Rail assembly as shown in Fig. #1. Step #2 is to mount Top Rail assembly on top of Mainside Legs (see Fig. #5A). Secure Top Rail to Mainside Legs using 1/2-13UNC x 2 HHCS (4 pcs. - 91247A720), 1/2 flat washers top and bottom (4 pcs. - 90126A033), 1/2 lock washers (4 pcs. - 91102A033) & 1/2-13UNC hex nut (4 pcs. - 90473A223).
- 7) Locate LH & RH Cross Rails see Fig.#3. Fig. #3 shows RH Cross Rail. The pin stops and the hose guide brackets are some of the determining factor between the LH and RH Cross Rails. Both pin stops and hose guide brackets go to the inside of the lift. Also locate cross rail leaf chain (2 pcs. - ALIG-412-097 - 206 1/4" long). Run chain through Cross Rail as shown in Fig.#3. Chain goes over the 2 1/4" pulley on the mainside end and under the pulley at the offside end. Do the same for both Cross Rails. After routing chains through Cross Rails Step #3 is to connect the end of the mainside chains to the chain connector at the bottom of both Mainside Legs using 5/16 x 1 1/4 shoulder bolt (2 pcs. - 91259A585) and 1/4-20UNC nylon lock nut (2 pcs. - 90640A129). **\*\*IMPORTANT - Leaf chain must be mounted vertically on the chain connector to eliminate any chance of binding or kinking. \*IMPORTANT\* - Note the orientation of the Top Rail to the location of the LH and RH Cross Rail on Fig. #5A. The Cross Rail with the short chain connector must connect to the long Top Rail chain and the tall chain connector must connect to the short Top Rail chain. If the Top Rail is rotated 180 degrees the chain connectors must be switched. The lift will lift load uneven if the connectors are not at the proper**

**location.** Do this before moving the Cross Rail into the Mainside Leg weldment. Now move Cross Rail into the leg to mount nylon rub blocks (3 pcs. – ALIG-412-019) and guide brackets (1/1 pc. – ALIG-412-082 & -083). The ALIG-412-082 always goes to the outside of the lift and ALIG-412-083 always goes to the inside of the lift. Move Cross Rail to the inside of the lift about an 1” off center and mount the double guide bracket with the rub block first. Slide rub blocks into each cut out of guide brackets (ALIG-412-082) see Fig. #5B. Take the guide assembly to the top of the inside leg and rotate the assembly so that it goes into the formed leg see Fig. #5C. Slide it down the leg and bolt it to the out side of the Cross Rail using ½-13UNC x ¾ HHCS (2 pcs. - 92865A710). Repeat the same procedure for Single Guide (ALIG-412-083).

- 8) Step #4 is to repeat the same procedure on the opposite mainside for the LH Cross Rails.
- 9) Step #5 is to locate the LH/RH Offside Legs shown in Fig. #2. LH Offside Leg is shown. See Fig. #5A for location on lift assembly. Slide LH Offside Legs into the RH Cross Rail about 11’-9 3/8” apart from the Mainside at the base plate. Repeat the mounting procedure of the guide brackets (ALIG-412-083 & -082) and the nylon rub blocks (ALIG-412-019). Guide brackets hold the Offside Leg the correct distance from the Mainside Leg.
- 10) Step #6 is to connect the cross rail leaf chain on the offside to the Theaded Chain Connector (1 pc. – ALIG-415-049) see Fig. #5D. Use the 5/16 x 1 ¼ shoulder bolt (2 pcs. - 91259A585) and ¼-20UNC nylon lock nut (2 pcs. – 90640A129) to connect the leaf chain to the chain connector.
- 11) Step #7 is to repeat Step #5 & #6 of the RH Offside Leg.
- 12) Step #8 is to move the Offside Legs apart to hold the 14’-8” dimension at the center to center of the legs and to anchor the legs to the concrete repeating Step #1.
- 13) Step #9 is to locate the LH/RH Track Weldm’t. (1/1 pcs. – (Std.) ALIG-412-020 or (Ext.) ALIG-412-220) and position them on top of the Cross Rails as shown in Fig. #5E. Hold 37 1/2” inside Track Weldm’t. and centered on the Cross Rails side to side.
- 14) Step #10 is to extend hydraulic cylinder which lower both Top Rail Chain to connect to chain connectors on Cross Rail. Use a 5/16 shoulder screw (2 pcs. – 91259A587) and ¼-20UNC nylon lock nut (2 pcs. – 90640A129) to secure the chain.
- 15) Step #11 is to mount the 3-way pneumatic valve, F/R/L air system & power unit to the LH Mainside Leg using the #6 pan screw, #6 lock washer #6 hex nut, #10 pan screw, #10 lock washer, #10 hex nut, 5/16-18UNC x 1” bolts, 5/16-18UNC hex nuts and 5/16 lock washers respectively see View A in Fig. #6B. Before connecting the hydraulic hoses from the power unit to the cylinder you must first install two 90 deg. fittings (2501-06-06) on the cylinder and two 90 deg. fittings with o-rings (6801-LL-06-06) on the power unit. The 108” hose (ALIF-412-029) goes from the fitting on the cylinder next to the rod to the fitting of the power unit on the side of the handle. The

48" hose (ALIF-412-030) goes from the fitting of the cylinder next to the power unit to the fitting of the power unit on the opposite side of the handle. Next connect the electricity to the power unit. Power requirements: 230 Volt, single phase power, 12 amp. Use separate circuit for each unit and protect each circuit with 30 amp time delay fuse or circuit breaker.

- 16) Fill pumping unit with hydraulic medium oil SAE-10 or equivalent. It will take approximately 3 US gallons. Automatic transmission fluid may be substituted.
- 17) Use plastic ties or steel loops to secure slack in hydraulic hose and hydraulic cylinders.
- 18) Before operating lift visually inspect lift to make sure the chains and hoses are not rubbing on hardware or lift parts.
- 19) Step #12 is to raise lift with track and rest on latch bar about 30" to 36" to secure Tracks on the Cross Rails and assemble the remaining parts and hardware on the Tracks. Use figure #4A, #4B and #4C.
- 20) Step #13 is to assemble and install the air hoses and fitting as shown in Fig. #6A and #6B. **Note: 1/8" and 3/8" tube run thru the hose brackets in the rear Cross Rail and thru the holes underneath the Track Weldm't. Air pressure requirements: 100 psi minimum to 120 psi maximum.** Use 3/8" Heli Tube (ALIG-415-119) to wrap 1/8" & 3/8 tube together.
- 21) OPTIONAL - Load both Air Jacks between Track Weldm't. one at each end with air fittings facing the front and rear of lift. Connect the two 1/4 retractable air hoses to the jacks (2 pcs. – 5245K12).
- 22) Connect the external air supply to 1/4 FNPT Air Ball Valve.
- 23) Again before operating lift visually inspect lift to make sure hoses are not rubbing on hardware or lift parts. Push button on power unit to raise lift until safety latches rise off the latch bar, then press the 3-Way Pneumatic Valve and at the same time pull release handle on the power unit to lower lift.
- 24) Raise lift about 60" and set safety latches on latch bar. Adjust latch bars on legs to set Track level. This is done by turning the 3/4-10UNC hex nut on the threaded rod of the latch bar.
- 25) Raise and lower lift repeatedly to purge air trapped in hydraulic lines and to adjust Cross Rails. Each Cross Rail must be synchronized as the lift moves up and down. Adjust Cross Rails by turning the 1" hex nut of the chain connector on the Offside Legs.
- 26) Refill tank with hydraulic oil.
- 27) After lift is leveled and operating properly, pour grout between the base plate and the concrete floor to stabilize the lift. Do not use lift for 24 hours.



### **30 DAY MAINTENANCE**

- 1) Inspect the chains for wear. Grease inside formed legs as needed.
- 2) Check equalizer cables regularly for proper tension and adjustment.
- 3) Inspect adapters and pads for damage or wear. Replace if necessary.
- 4) Inspect all hydraulic lines and fittings for leaks and tighten if necessary.
- 5) Check locking latches and releases for proper operation.
- 6) Check automatic arm lock device for proper operation.

## TROUBLE SHOOTING GUIDE

### POSSIBLE PROBLEM

### POSSIBLE CAUSE & SOLUTIONS

1. MOTOR DOES NOT RUN

- A) Breaker tripped or fuse blown
- B) Motor thermal overload tripped. Wait for overload to cool.
- C) Check thermal overload in starter box (three phase only). Push to reset.
- D) Defective control switch, replace
- E) Faulty wiring connections. Call electrician.

2. MOTOR RUNS BUT THE LIFT WILL NOT RAISE OR HOLD A LOAD

- A) A foreign object under check valve. Push handle down and push “raise” switch. Foreign matter should release under pressure.
- B) Remove check valve. Clean and replace.
- C) Oil level low: check oil reservoir. With carriage in the down position, pump reservoir should be full.

3. MOTOR RUNS BUT THE LIFT PICKS UP PARTIAL LOAD ONLY.

- A) Relief valve setting is too low. Remove back hexcap on pump and adjust valve clockwise.
- B) Hydraulic seals damaged (call factory for instructions)

4. OIL BLOWS OUT BREATHER

- A) Oil reservoir overfilled
- B) Lift lowered too quickly while under heavy load.

5. LIFT MAKES A GROANING SOUNDING WHEN RAISING OR LOWERING.

- A) Bleed cylinder manually.
- B) Add an ounce of oil to the air side of the piston.

6. LIFT RAISES UNEVENLY

- A) Chain are not properly adjusted or tightened.
- B) Use lighter weight oil in the pump.

7. LIFT DOES NOT LOWER

- A) Adjust yokes out at pneumatic cylinders in the Cross Rails

## PARTS & SHIPPING LIST

PART NUMBER	DESCRIPTION	QTY.	
	<b>Ramp Assy.</b>	<b>2</b>	
ALIG-412-01	Ramp Weldm't.	2	
5304Z	52 O.D. x 20 I.D. x 22W DS Bearing	4	
98410A128	0.75 Dia. Retainer Ring	6	
ALIG-412-101	¾ Dia. Ramp Pins	2	
	<b>Top Rail Assy.</b>	<b>1</b>	
ALIG-412-001	Std. Top Rail Weldm't.	1	
(ALIG-415-201)	Ext. Top Rail Weldm't.	1	
AA-3515001	3.50 Dia. 72" Stroke Hyd. Cylinder	1	
98023A045	2.00 SAE Flat Washer	2	
98410A152	2.000 Dia. Retainer Ring	2	
98410A249	1.375 Dia. Retainer Ring	3	
98410A133	1.000 Dia. Retainer Ring	1	
98381A593	0.313 Dia. x 2.5 Lg. Dowel Pin	2	
ALIG-412-009	Cylinder Chain Connector	1	
ALIG-412-098	BL646, 127 Pitch Male Ends, Std. Short Top Rail Chain	1	
(ALIG-415-298)	BL646, 153 Pitch Male Ends, Ext. Short Top Rail Chain	1	
GL-12-053	5.5 Dia. Roller	2	
GL-12-056	4.0 Dia. Pulley	3	
GL-12-096	BL646, 347 Pitch Male Ends, Std. Long Top Rail Chain	1	
(ALIG-415-296)	BL646, 399 Pitch Male Ends, Ext. Long Top Rail Chain	1	
GL-12-100	1 Dia. Cylinder Pin	1	
GL-12-101	1 3/8 Dia. Pulley Pin	3	
2501-06-06	0.375MNPT x 0.375MJIC 90 Deg. Adapter	2	HK
6801-LL-06-06	0.375MORB x 0.375MJIC 90 Deg. Adapter w/O-ring	2	HK
3225T6	¾" Rubber Cushion Steel Loops (Optional)	4	HK
91247A720	½-13UNC x 2.0 HHCS Grd. 5	4	HK
90473A223	½-13UNC Hex Nut Grd. 2	4	HK
91102A033	½ Lock Washer	4	HK
90126A033	½ SAE Flat Washer	8	HK
7130K55	11" Black Ties	12	HK
ALIF-412-029	0.375FJICS Hose x 108"	1	PKG
ALIF-412-030	0.375FJICS Hose x 48"	1	PKG

<b>LH/RH Cross Rail Assy.</b>		<b>1/1</b>	
ALIG-412-060L/R	LH/RH Cross Rail Weldm't.	1/1	
6498K334-1.00	0.75 Dia. x 1.0 Stroke Pneum Cylinder	4	
6498K42	0.75 Dia. Cylinder Yokes	4	
6498K72	0.75 Dia. Cylinder Brackets	4 Sets	
5315	0.375 Dia. x 0.41W x 1.00 Lg. Ext. Spring	4	
SPC-2001	1/8 MNPT x 1/8 Push-On Fitting	4	
90096A242	#10-24 Hex Head Thread Cutting Screws	8	
91251A542	1/4-20UNC x 1.0 Lg. SHCS	4	
91251A546	1/4-20UNC x 1.5 Lg. SHCS	4	
90473A029	1/4-20UNC Hex Nut Grd. 2	4	
90126A038	1" SAE Flat Washer	4	
91102A029	1/4 Lock Washer	12	
98410A128	0.750 Dia. Retainer Ring	6	
98410A133	1.000 Dia. Retainer Ring	4	
91309A537	1/4-20UNC x 0.50 Lg. HHCS Grd. 2	8	
ALIG-412-007	CR Cover Plate	4	
ALIG-412-076	Safety Locks	4	
ALIG-412-088	3/4 Dia. Pulley Pin	6	
ALIG-412-089	1 Dia. Safety Latch Pin	4	
ALIG-412-090	Mach. Chain Connector 3" Lg. (LH Cross Rail)	1	
ALIG-412-090A	Mach. Chain Connector 2 1/4" Lg. (RH Cross Rail)	1	
ALIG-412-102	Safety Latch Spacer	4	
GL-12-055	2.25 Dia. Pulley	4	
91259A585	0.313 Dia. 1.25 Lg. Shoulder Bolt	4	HK
91259A587	0.313 Dia. 1.50 Lg. Shoulder Bolt	2	HK
90640A129	1/4-20UNC Nylon Lock Nut	6	HK
92865A710	1/2-13UNC x 0.75 Lg. HHCS Grd. 2	16	HK
ALIG-412-019	Nylon Rub Blocks	12	PKG

<b>LH/RH Mainside Leg Assy.</b>	<b>1/1</b>
<b>LH/RH Offside Leg Assy.</b>	<b>1/1</b>

ALIG-412-070L/R	LH/RH Mainside Leg	1/1	
ALIG-412-071L/R	LH/RH Offside Leg	1/1	
ALIG-412-084	Latch Bar Weldm't.	4	
ALIG-412-105	Holding Bracket	24	
90272A247	#10-24UNC x 1.00 Pan Head Phillips Screw	24	
91102A011	#10 Lock Washer	24	
95462A538	3/4-10UNC Hex Nut Grd. 2	8	
91247A583	5/16-18UNC x 1.0 Lg. HHCS Grd. 5	4	HK
95473A030	5/16-18UNC Hex Nut Grd. 2	8	HK
91102A030	5/16 Lock Washer	4	HK
92865A720	1/2-13UNC x 2.0 Lg. (Full Thrd) HHCS Grd. 5	16	HK
90473A223	1/2-13UNC Hex Nut Grd. 2	16	HK
91578A501	3/4-10UNC x 5 Lg. Anchor Bolts w/SAE FW & Hex Nuts	16	HK

94846A555	1-14UNF Hex Nut Grd. 5	4	HK
90126A038	1.0 SAE Flat Washer	2	HK
ALIG-415-049	Threaded Chain Connector	2	PKG

**LH/RH Track Assy. 1/1**

ALIG 412-020L/R	Std. LH/RH Track Weldm't.	1/1	
(ALIG 412-220L/R)	Ext. LH/RH Track Weldm't.	1/1	
3896T1	1/16 Oval Sleeve Alum. Ferrules	16	
3461T82	1/16 Wire Rope (8 pcs – 12" lg.)	8 Ft.	
ALIG-412-008	Slip Plate Pin	8	
9614K37	1.0 Dia. Delrin Ball	56	HK
92865A714	½-13UNC x 1.25 Lg. HHCS Grd. 5	38	HK
90473A223	½-13UNC Hex Nut Grd. 2	54	HK
91102A033	½ Lock Washer	54	HK
92865A841	¾-10UNC x 1.75 Lg. HHCS Grd. 5	10	HK
90473A036	¾-10UNC Hex Nut Grd. 2	10	HK
91102A036	¾ Lock Washer	10	HK
90566A031	3/8-16UNC Thin Nylon Lock Nut.	8	HK
91090A115	3/8 Fender Washer x 1 ½ OD	16	HK
93548A644	3/8-16UNC Carriage Bolt x 5 Lg.	8	HK
ALIG-412-099	½-13UNC x 3.25 x 6.50 U-Bolts	8	HK
ALIG-412-046	0.25 x 2.50 x 71.625 CDFB, 1018	4	PKG
ALIG-412-047	16 Ga. MSSH x 5.00 x 35.00, A366	8	PKG
ALIG-412-051	Front Stop Weldm't.	2	PKG
ALIG-412-055	Ramp Support Weldm'.	2	PKG
ALIG-412-093	Track Steps	2	PKG
ALIG-412-101	Ramp Pivot Pin	2	PKG
ALIG-412-107	Quick Disconnect Brkt.	2	PKG
ALIG-412-109	Elect. Box Brkt.	1	PKG

**Misc. Parts**

92865A719	½-13UNC x 1.75 HHCS Grd. 5	16	
91236A724	½-13UNC x 3.0 HHCS Grd. 5	4	
90473A223	½-13UNC Hex Nut Grd. 2	20	
90096A242	#10-24 HH Thread Cutting Screw	4	
91102A033	½ Lock Washer	20	
90126A033	½ SAE Flat Washer	40	
4534K42	*¼ NPTF FM Seal Hex Socket Plug (ALIF-209 Cyl.)	1	HK
60115K39	F/R/L Air System	1	HK
6464K18	3-Way Pneumatic Valve	1	HK
SPC-2001	1/8 MNPT x 1/8 Push-On Fitting (Plastic)	3	HK
SPE-20	1/8 Push-On Union Tee (Plastic)	3	HK
SPC-6002	¼ MNPT x 3/8 Push-On Fitting (Plastic)	8	HK

SPE-60	3/8 Push-On Union Tee (Plastic)	6	HK
47865K21	1/4 FNPT x 1/4 FNPT Ball Valve (Brass)	1	HK
5485K22	1/4 MNPT x 1/4 MNPT Hex Nipple (Brass)	2	HK
50785K72	1/4 FNPT Tee Connector (Brass)	1	HK
50785K61	1/4 MNPT x 1/8 FNPT Hex Bushing (Brass)	1	HK
50785K41	1/8 MNPT x 1/8 FNPT 90 Deg. Street Elbow (Brass)	2	HK
91247A583	5/16-18UNC x 1.0 Lg. HHCS Grd. 5	2	HK
95473A030	5/16-18UNC Hex Nut Grd. 2	2	HK
91102A030	5/16 Lock Washer	2	HK
94070A153	#6-32UNC x 1.00 Pan Head Phillips Screw	2	HK
91102A007	#6 Lock Washer	2	HK
90480A007	#6-32UNC Hex Nut Grd. 2	2	HK
6536K18	1/4 MNPT x 1/4 F Quick Disconnect Hose Coupling (Ind.)	6	HK
5245K12	1/4 MNPT x 1/4 Self Retracting Nylon Air Hose 25'	2	HK
AH-1008	Power Unit	1	PKG
ALIG-412-119	Turntable Cover (Only on Extended Lifts)	2	PKG
ALIG-415-097	BL644, 275 Pitch Male Ends, Cross Rail Chain	2	PKG
ALIG-415-117	45' - PT23002BK - 1/8 Black Tube	1	PKG
ALIG-415-118	55' - PT24006BK - 3/8 Black Tube	1	PKG
ALIG-415-119	6' - HT-00375 - 3/8 Heli Tube	1	PKG

#### OPTIONAL EQUIPEMENT

ALIF-ARJ-06K	6K Air Roller Jack	2	PKG
ALIF-TT1	13" Dia. Turntables	2	PKG

\*\*\* Note: All hardware unless specified is grade 2. All hardware is zinc coated unless specified. Parts with PKG at the end are packed on the lift and parts with HK at the end are packaged in a box and put on the lift.

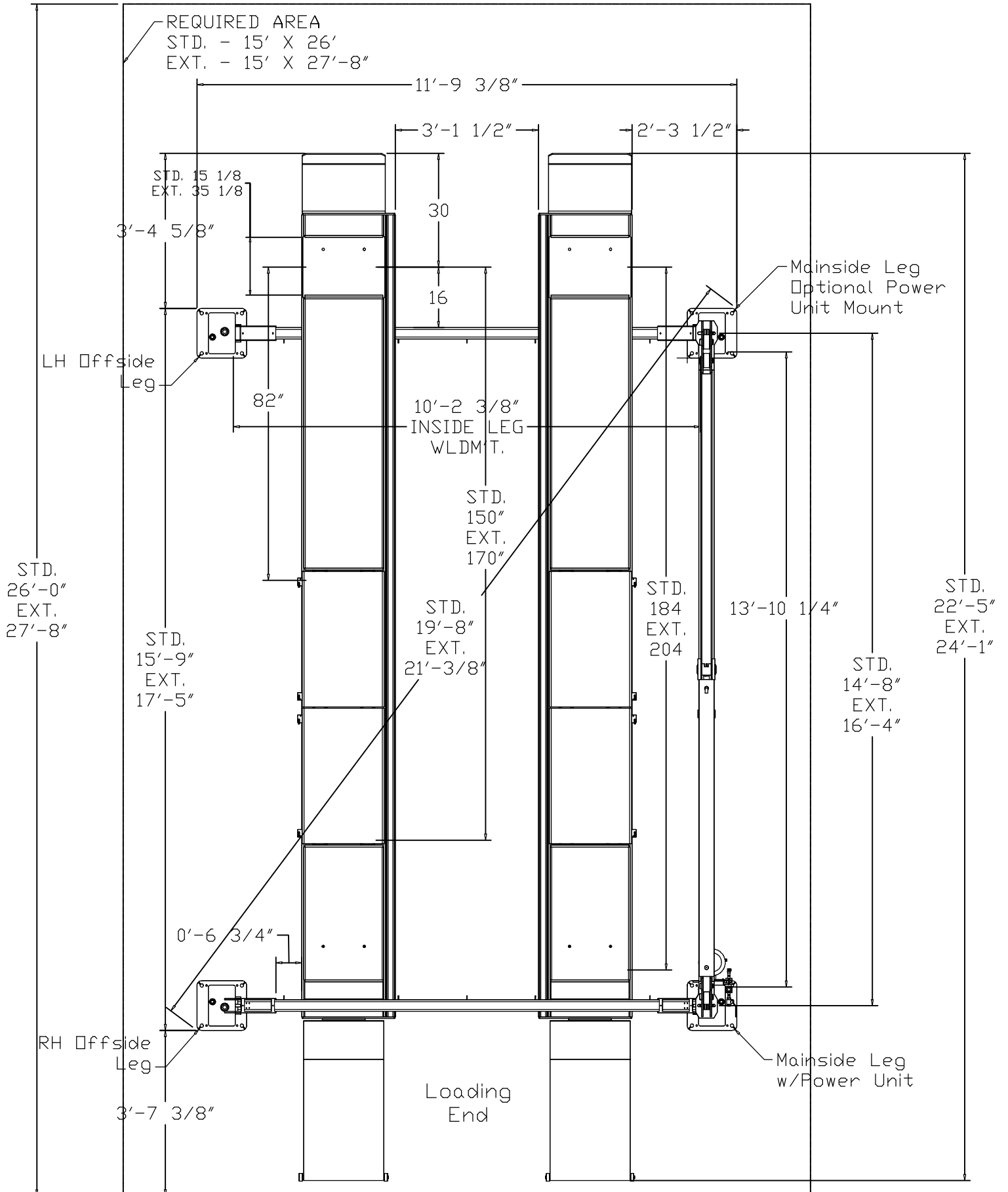
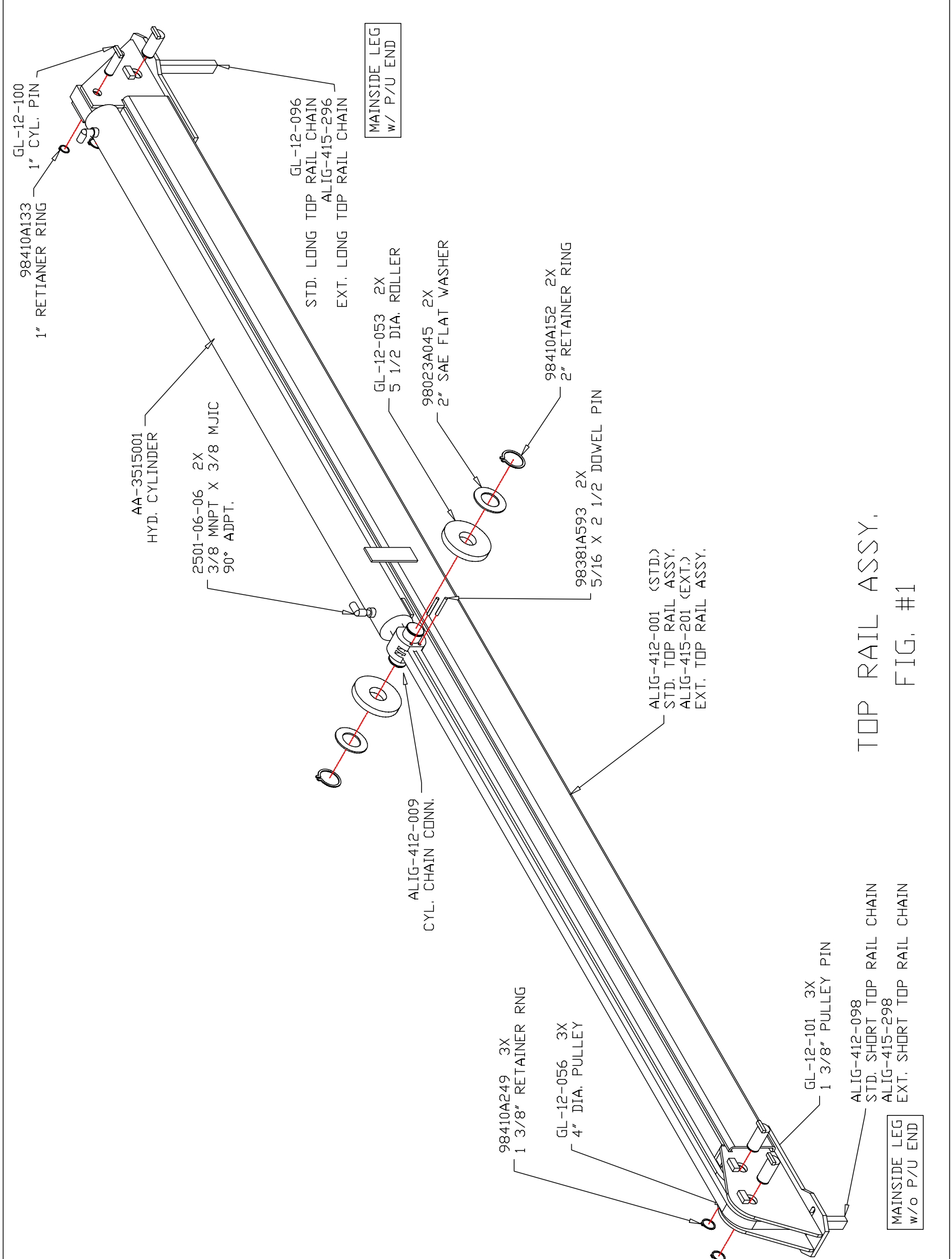

FIG #1 WFP15ARD - LAYOUT &  
 INSTALLATION SPECIFICATION



98410A133  
1" RETIANER RING

GL-12-100  
1" CYL. PIN

AA-3515001  
HYD. CYLINDER

2501-06-06 2X  
3/8 MNPT X 3/8 MJIC  
90° ADPT.

GL-12-096  
STD. LONG TOP RAIL CHAIN  
ALIG-415-296  
EXT. LONG TOP RAIL CHAIN

MAINSIDE LEG  
w/ P/U END

GL-12-053 2X  
5 1/2 DIA. ROLLER

98023A045 2X  
2" SAE FLAT WASHER

98410A152 2X  
2" RETAINER RING

98381A593 2X  
5/16 X 2 1/2 DOWEL PIN

ALIG-412-001 (STD.)  
STD. TOP RAIL ASSY.  
ALIG-415-201 (EXT.)  
EXT. TOP RAIL ASSY.

ALIG-412-009  
CYL. CHAIN CONN.

98410A249 3X  
1 3/8" RETAINER RING

GL-12-056 3X  
4" DIA. PULLEY

GL-12-101 3X  
1 3/8" PULLEY PIN

ALIG-412-098  
STD. SHORT TOP RAIL CHAIN  
ALIG-415-298  
EXT. SHORT TOP RAIL CHAIN

MAINSIDE LEG  
w/o P/U END

TOP RAIL ASSY.  
FIG. #1



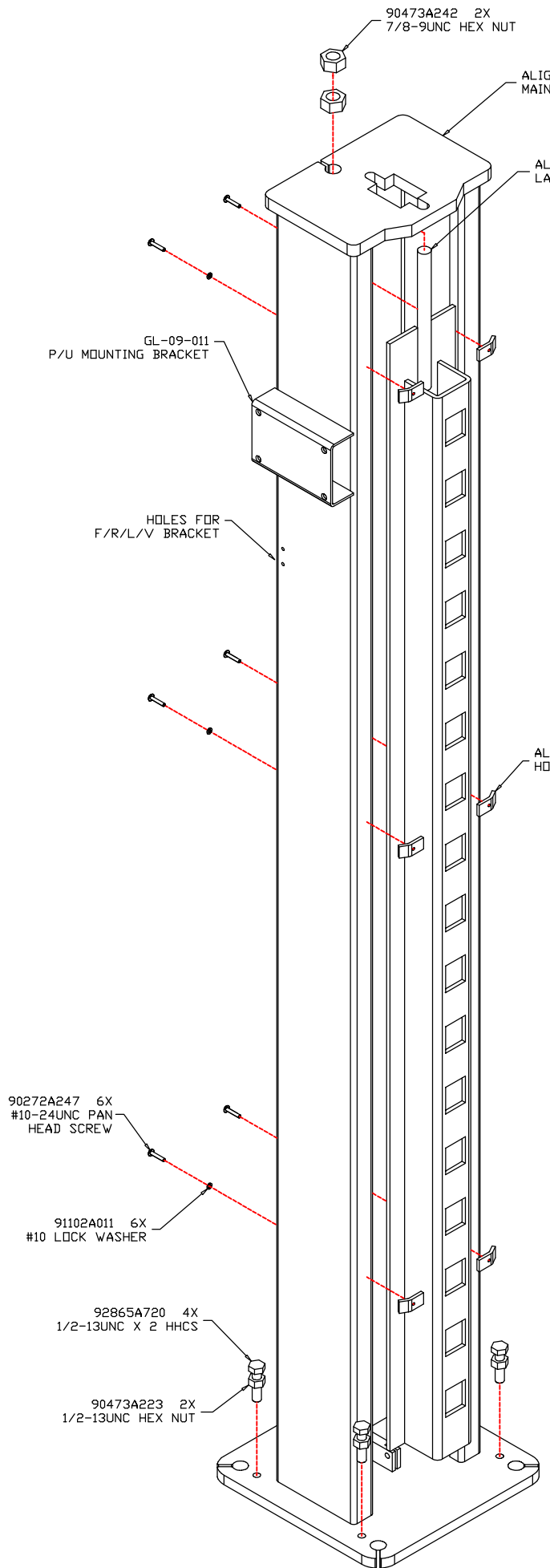

MAINSIDE LEG ASSY. LH/RH  
LH MAINSIDE LEG ASSY. SHOWN

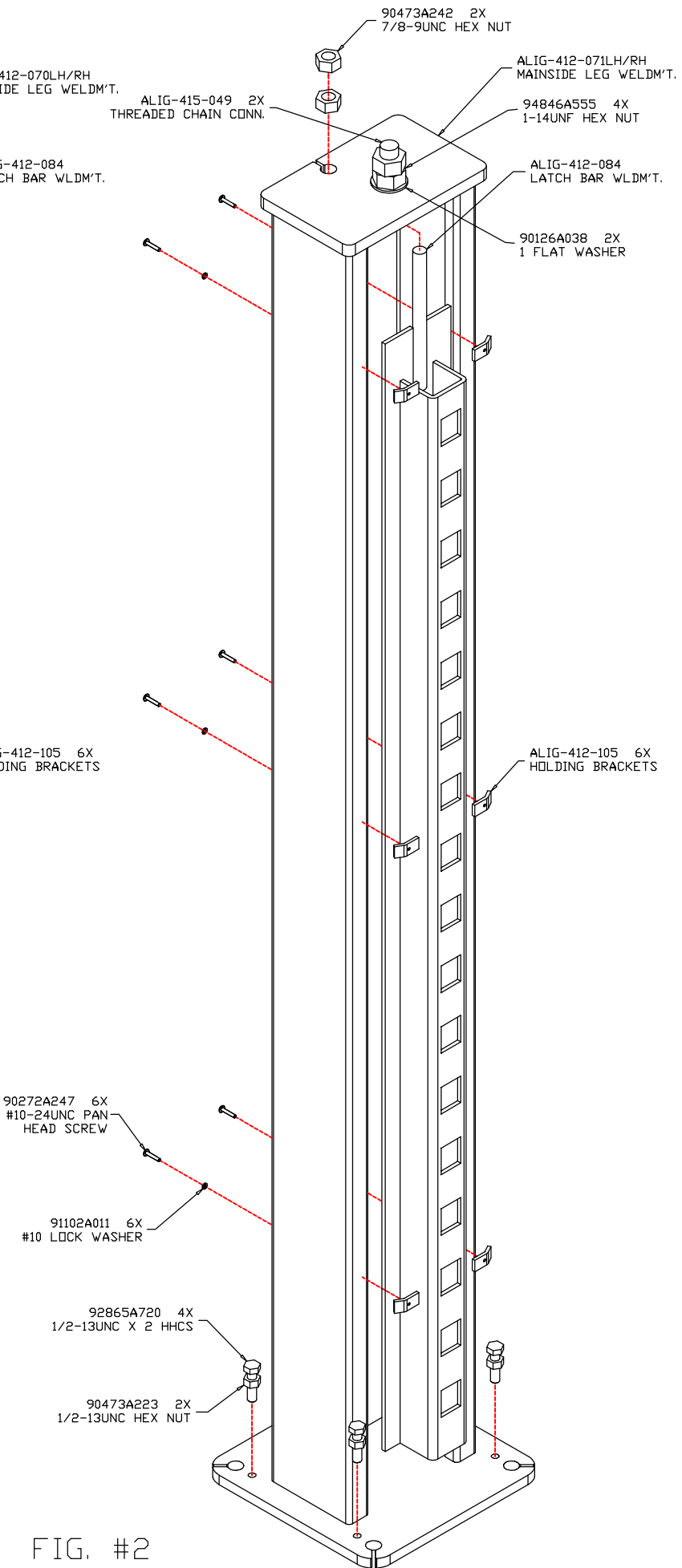

OFFSIDE LEG ASSY. LH/RH  
LH OFFSIDE LEG ASSY. SHOWN

FIG. #2

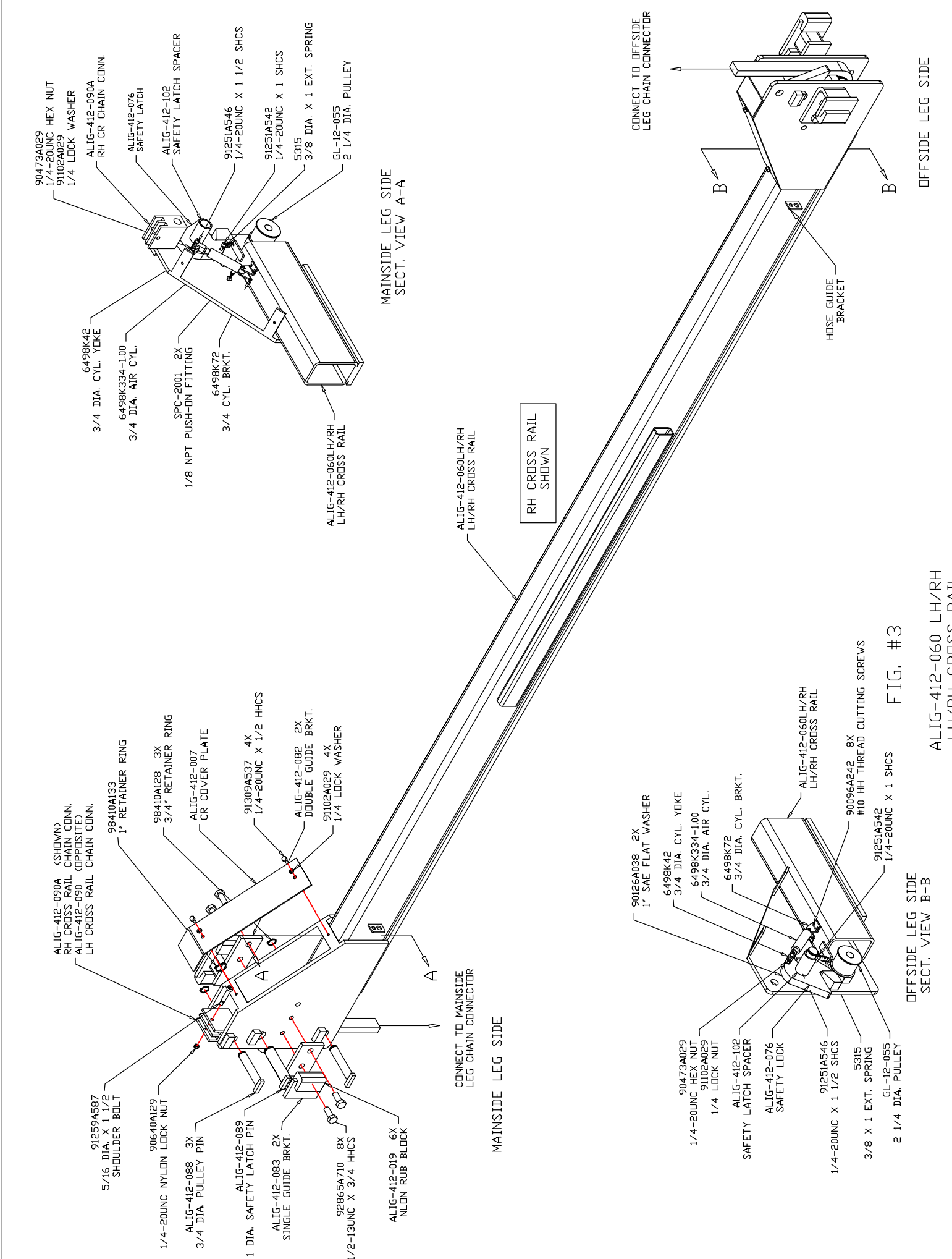

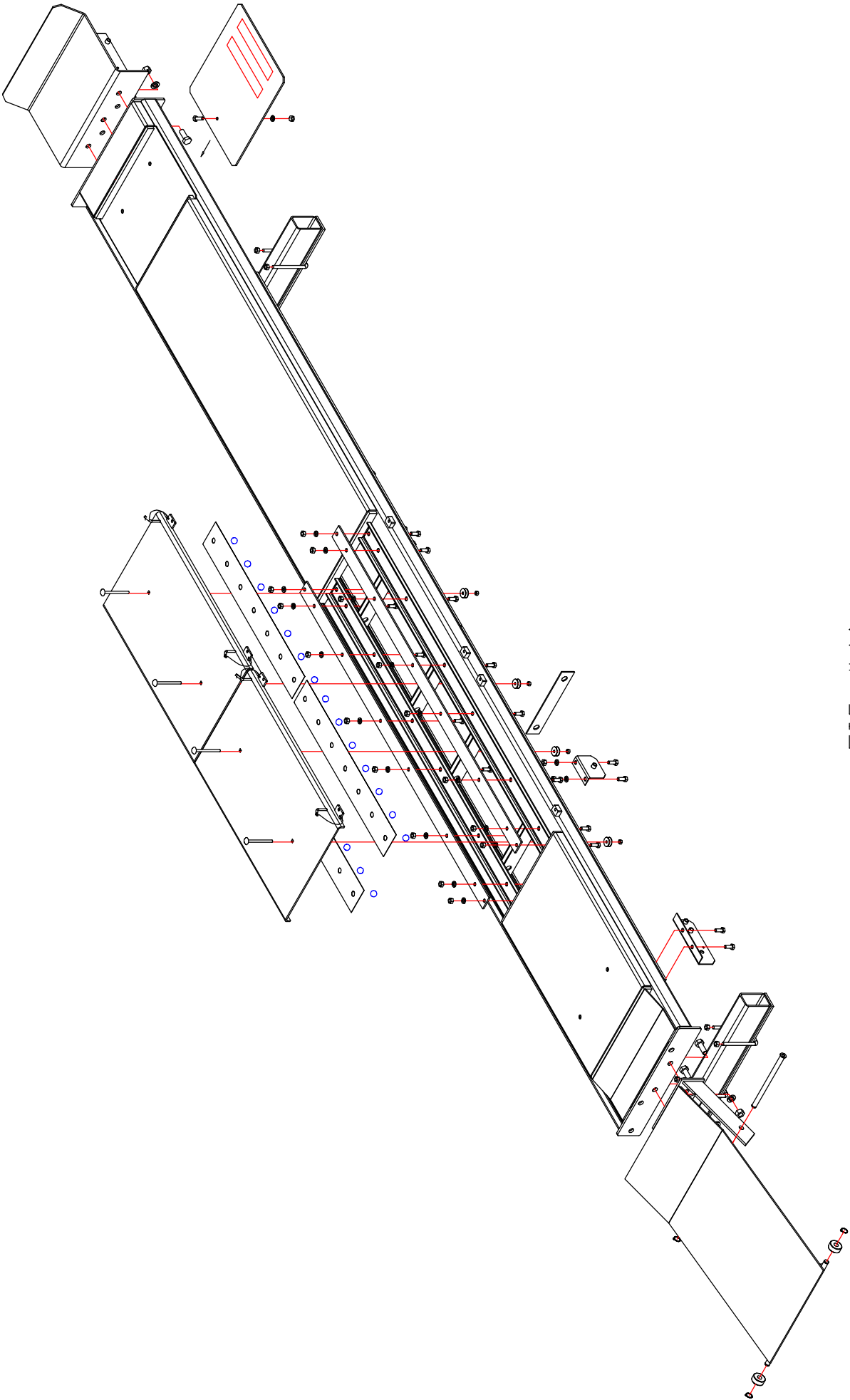

FIG. #4A

TRACK ASSY.

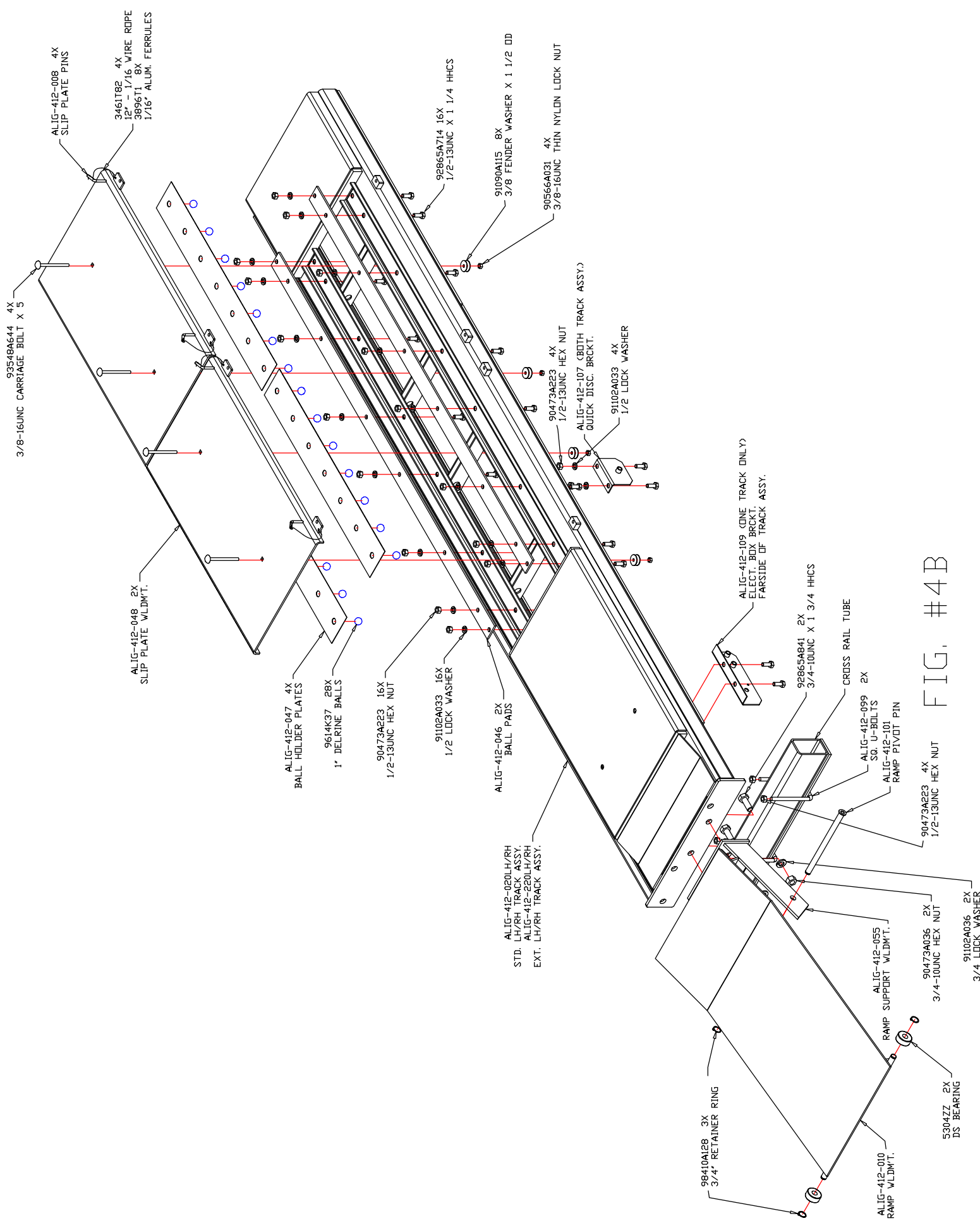

FIG. #4B

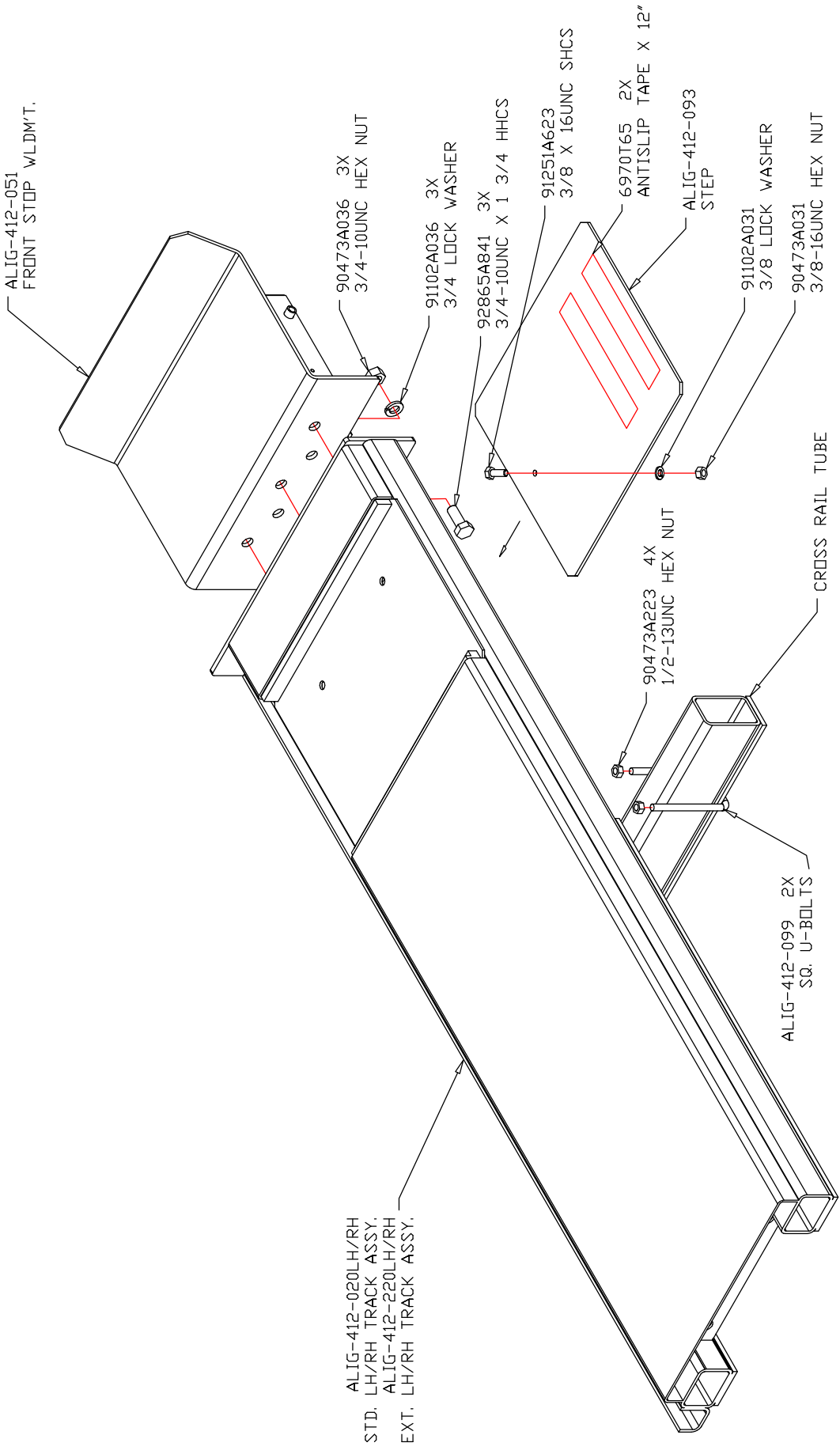

FIG. #4C

**\*NOTE:**

- POWER UNIT CAN BE MOUNTED ON EITHER MAINSIDE LEG.
- MAINSIDE LEGS CAN BE LOCATED ON EITHER SIDE OF LIFT.
- IF MAINSIDE LEGS ARE SWITCHED TO OPPOSITE SIDE OF LIFT THEN CROSS RAILS MUST ALSO BE CHANGED IN RESPECT.
- THE ROUTING OF THE HYDRAULIC AND AIR LINES CHANGE DEPENDING ON WHERE THE POWER UNIT IS LOCATED AND WHICH SIDE THE MAINSIDE LEGS ARE LOCATED ACCORDING TO THE LIFT.

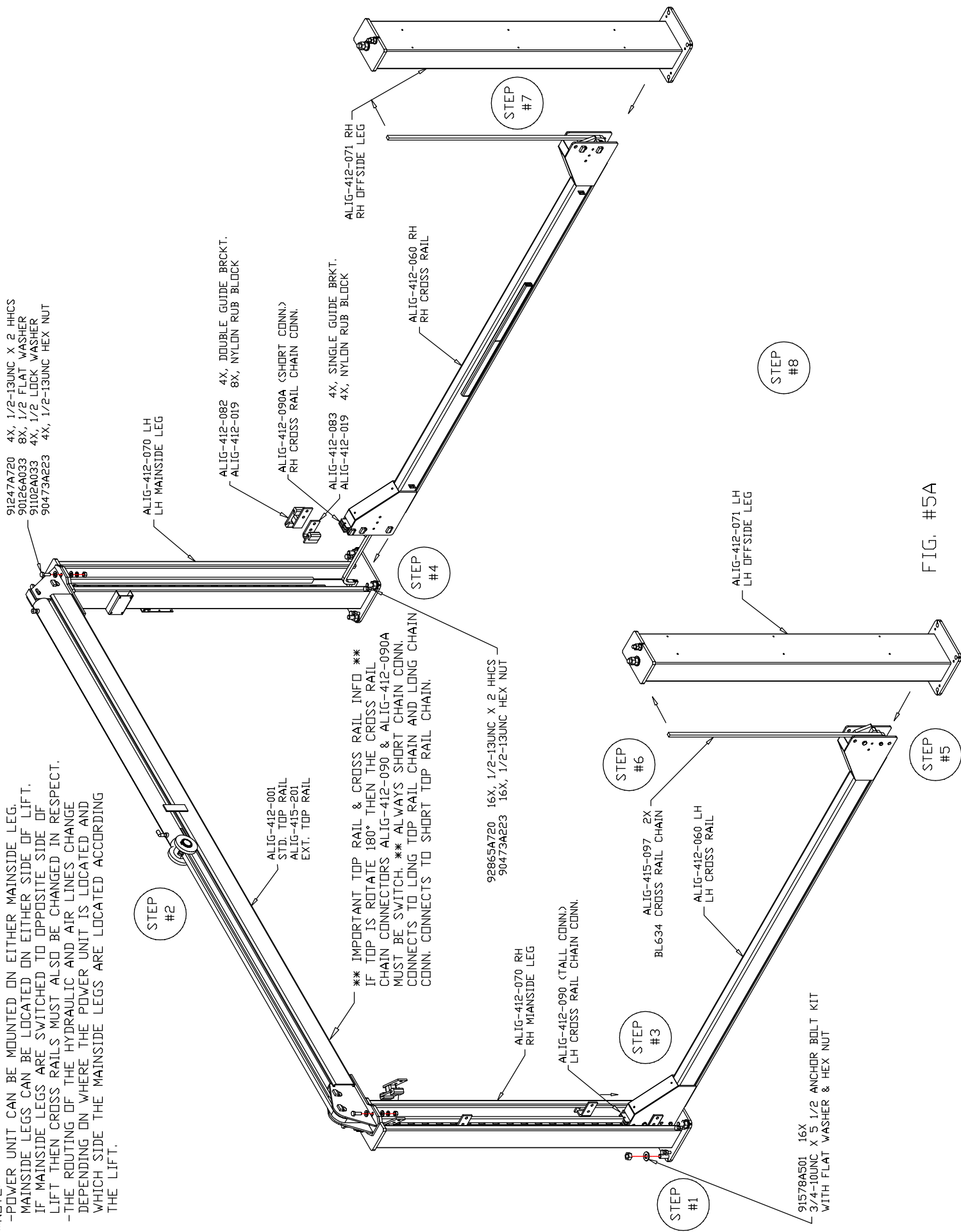

FIG. #5A

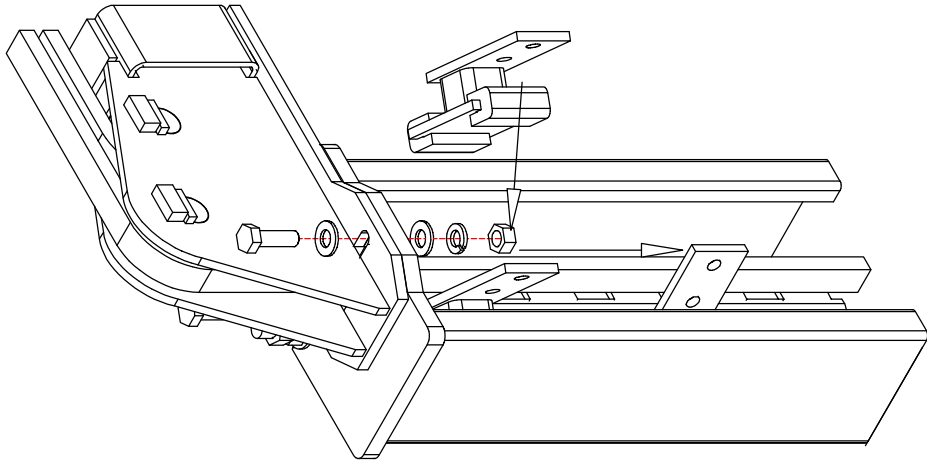

FIG. #5C

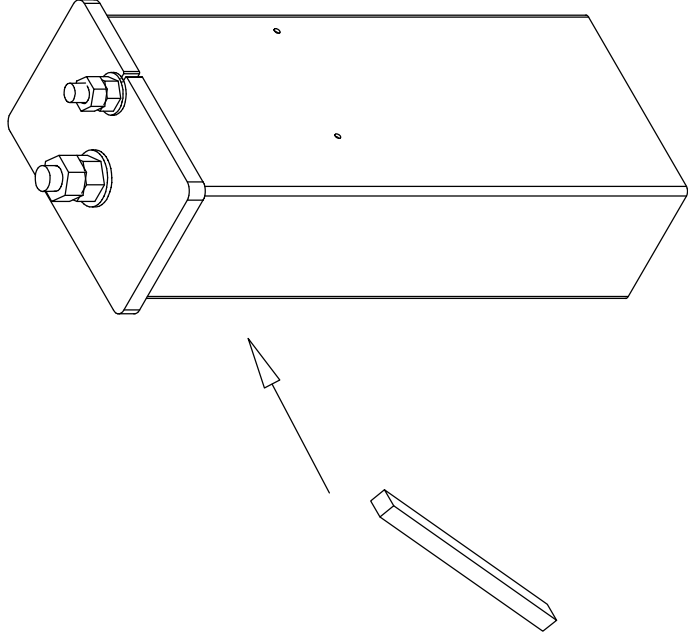

FIG. #5D

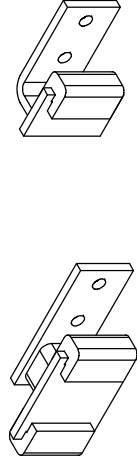

FIG. #5B

\*NOTE:  
 -POWER UNIT CAN BE MOUNTED ON EITHER MAINSIDE LEG.  
 -MAINSIDE LEGS CAN BE LOCATED ON EITHER SIDE OF LIFT.  
 IF MAINSIDE LEGS ARE SWITCHED TO OPPOSITE SIDE OF LIFT THEN CROSS RAILS MUST ALSO BE CHANGED IN RESPECT.  
 -THE ROUTING OF THE HYDRAULIC AND AIR LINES CHANGE DEPENDING ON WHERE THE POWER UNIT IS LOCATED AND WHICH SIDE THE MAINSIDE LEGS ARE LOCATED ACCORDING TO THE LIFT.

\*\* IMPORTANT TOP RAIL & CROSS RAIL INFO \*\*  
 IF TOP IS ROTATE 180° THEN THE CROSS RAIL CHAIN CONNECTORS ALIG-412-090 & ALIG-412-090A MUST BE SWITCH. \*\* ALWAYS SHORT CHAIN CONN. CONNECTS TO LONG TOP RAIL CHAIN AND LONG CHAIN CONN. CONNECTS TO SHORT TOP RAIL CHAIN

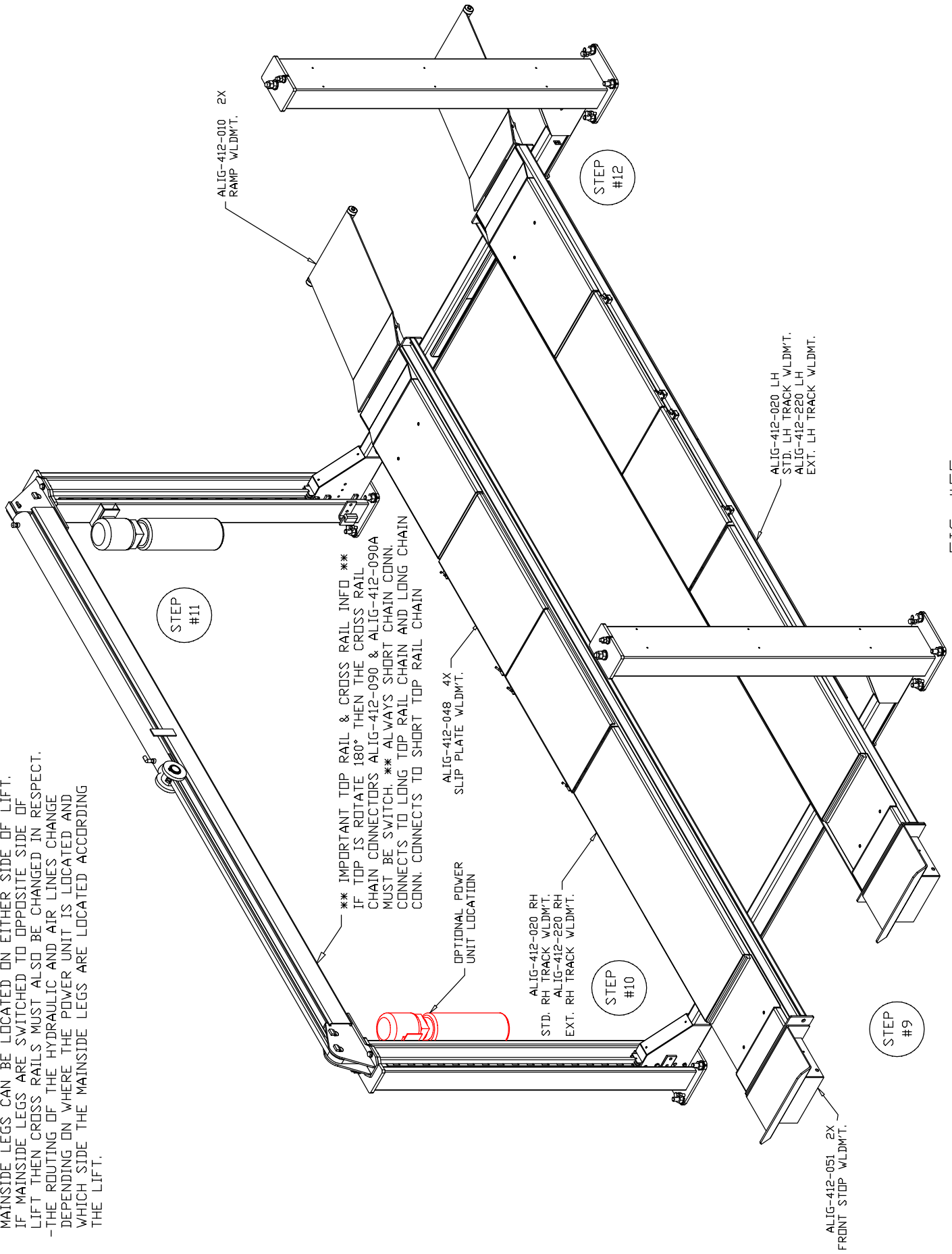

FIG. #5E



\*NOTE:  
 THIS IS THE RECOMMENDED CONFIGURATION FOR THE AIR  
 AND HYDRAULIC LINES, BUT THE CONFIGURATION COULD  
 VARY DEPENDING ON CUSTOMER PREFERENCE. POWER UNIT  
 CAN BE MOUNTED ON EITHER MAIN SIDE LEG.

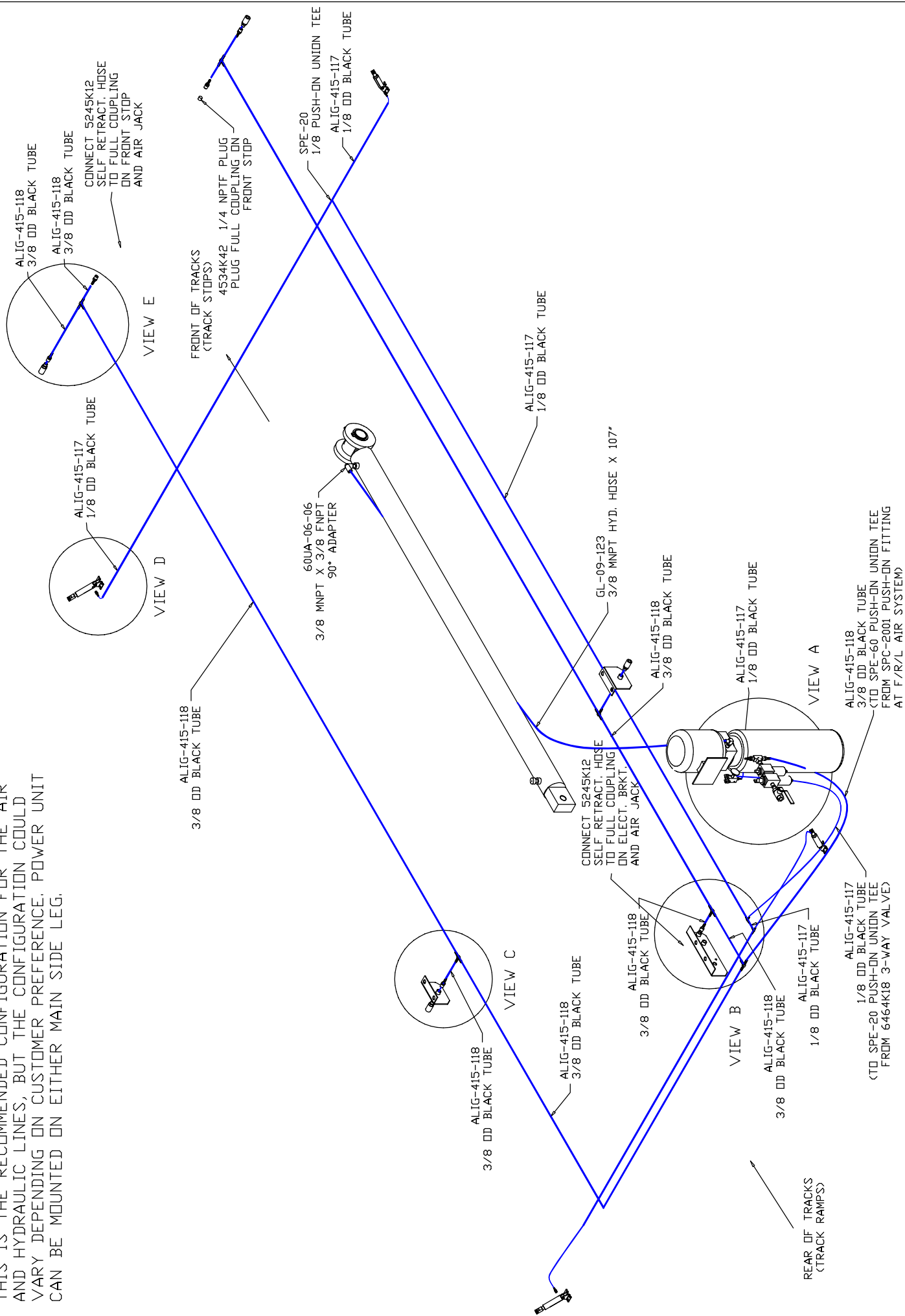
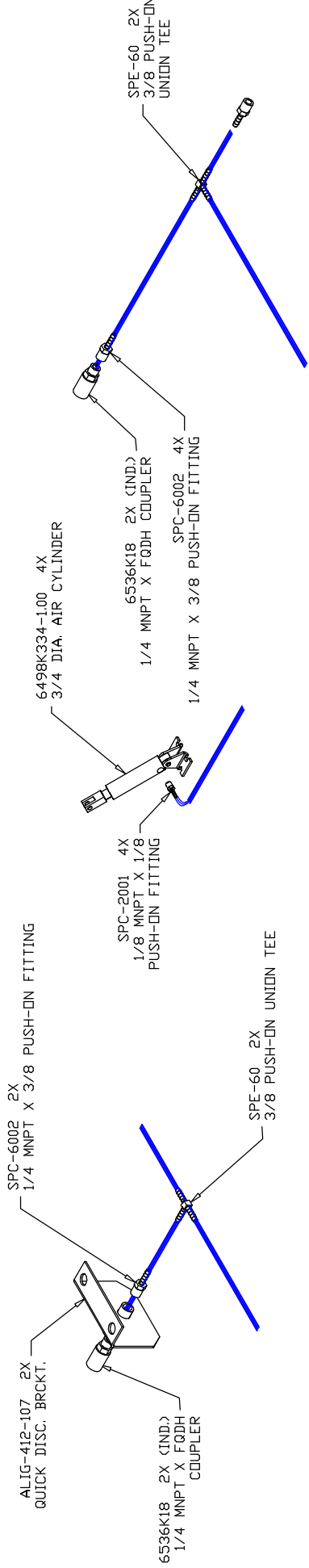

FIG #6A



VIEW C

VIEW D

VIEW E

AH-1009 POWER UNIT  
 91247A583 4X (5/16-18UNC X 1 HHCS),  
 95473A030 8X (5/16-18UNC HEX NUT),  
 & 91102A030 4X (5/16 LOCK WASHER)  
 FOR MOUNTING ON ALIG-412-070LH LEG WLD'T.

50785K41 2X  
 1/8 MNPT X 1/8 FNPT  
 90° STREET ELBOW

6464K18 3-WAY PNEUM. VALVE  
 USE 90272A153 2X (#6 PAN SCREWS),  
 91102A007 2X (#6 LOCK WASHER),  
 & 90480007 2X (#6 HEX NUT) FOR  
 MOUNTING ON ALIG-412-070LH/RH  
 LEG WLD'T.

5485K22 2X  
 1/4 MNPT X 1/4 MNPT  
 HEX NIPPLE

47865K21  
 1/4 FNPT X 1/4 FNPT  
 AIR BALL VALVE

6801-LL-06-06 2X  
 3/8 MORB X 3/8 MJIC 90°  
 ADAPTER W/D-RING

50785K61 1X  
 1/4 MNPT X 1/8 FNPT  
 HEX BUSHING

ALIG-412-109  
 ELECT. BOX BRCKT.

SPC-2001 3X  
 1/8 MNPT X 1/8  
 PUSH-ON FITTING

50785K72  
 1/4 FNPT TEE CONNECTOR

SPC-6002 2X  
 1/4 MNPT X 3/8 PUSH-ON FITTING

42035 F/R/L AIR SYSTEM  
 91247A583 2X (5/16-18UNC X 1 HHCS),  
 95473A030 2X (5/16-18UNC HEX NUT),  
 & 91102A030 2X (5/16 LOCK WASHER) FOR  
 MOUNTING ON ALIG-412-070LH LEG WLD'T.

SPC-6002  
 1/4 MNPT X 3/8 PUSH-ON FITTING

SPE-60 2X  
 3/8 PUSH-ON UNION TEE

SPE-20 2X  
 1/8 PUSH-ON UNION TEE

VIEW A

FIG #6B

VIEW B