

MANUAL FOR

WFP12R

STD. 4 POST LIFTS

&

WFP12R-E

EXT. 4 POST LIFTS

WHIP INDUSTRIES, INC
3010 S MAIN ST.
FORT WORTH, TEXAS 76110
PH (800) 256-7391 FAX (817) 289-1412
E-MAIL: WhipInd@whipindustries.com

Rev. B

INTRODUCTION

The four post lift consists of four vertical posts with runway tracks between the posts. The lifting is done by a hydraulic cylinder coupled to heavy duty leaf chains which roll over sealed roller bearings. A 2 H.P. power unit supplies up to 2,000 p.s.i. to the cylinder for the lifting. Each post is equipped with a spring loaded safety latch that is activated only when there is slack in the chains. There is also a safety latch on the cylinder in case of a hydraulic failure.

The installation is a relatively simple task that can be accomplished by 3 men in just a few hours. A forklift or a fourth man will be helpful while raising the toprail into place and installing the runways.

TO PREVENT MISTAKES AND SAVE TIME, PLEASE READ THIS MANUAL COMPLETELY BEFORE BEGINNING THE INSTALLATION.

LIFT LOCATION

Choose your installation site carefully. Keep in mind doors, power supply, and overhead obstructions. These are all important considerations that will help make the lift the most valuable tool in your shop.

The most important thing to look for is a good concrete floor. It should be a minimum of 4" thick and 3,000 p.s.i. with steel reinforcement. Pads must be at least 24"x 24"x 4" thick with steel reinforcement.

There must be adequate overhead clearance to raise vehicles 6 feet above the ground. The recommended minimum ceiling height is 10 feet.

The toprail can be placed on the left or right side.

TOOLS REQUIRED

Concrete rotary hammer drill with 3/4" carbide bit

Open end wrenches: 1/2", 9/16", 11/16", 3/4"

Ratchet driver

Sockets: 3/4", 1/2" deep

12" crescent wrench

Hammer

Needle nose pliers

Level

Fish tape

25' tape measure

Chalk line

Small drift punch

Step ladder

4 wooden blocks (2 x 4's)

3 gallons non-detergent hydraulic fluid 10 wt.

(example: Mobil DTE 25, Texaco HD 46, or Dextron II & III ATF)

ANCHORING TIP SHEET

- 1. Anchors must be at least 5” from the edge of the slab or any seam.**
- 2. Use a concrete hammer drill with a 3/4 carbide bit.**
- 3. Do not use a worn bit.**
- 4. Drill in a perpendicular line with the hole.**
- 5. Do not apply excessive pressure to the drill. Let the drill do the work.**
- 6. Lift the drill up and down occasionally to remove residue and to reduce binding.**
- 7. Drill the hole to a depth equal to the length of the anchor, or completely through the slab.**
- 8. For better holding power, blow all dust and residue from hole before driving anchor into hole.**
- 9. Place a flat washer over threaded end of anchor. Spin nut 1/2” down past end of anchor. Carefully tap anchor into the concrete until nut and flat washer are against base plate. Do not use an impact wrench to tighten.**

INSTALLATION

1. Determine the location for the lift. Keep in mind overhead clearances. Ten feet is the minimum recommended ceiling height. Allow 2 ft. for approach ramp.
2. Determine which side of the lift the toprail and power unit are to be on. This is called the MAINSIDE. The other side is referred to as the OFFSIDE. Ease of entry and exit from vehicles, type of work being done, and required placement of the power unit on the toprail side are all considerations.
3. After determining the location, and remembering to allow for the approach ramp, chalk a rectangular square using the appropriate dimensions given in **Fig.1**. Measure diagonally to check for squareness. The four chalked corners represent the outside leg base corners of each post.
4. After determining the mainside (the side the toprail is to be placed on), stand the two mainside legs upright inside the chalk lines, with each leg facing inside. One of the two legs comes with a factory installed power unit mount. This leg is to be placed as follows:
 - If toprail/mainside is to be on the left as you approach, this post must be at the left front corner. See **Fig 2**.
 - If toprail/mainside is to be on the right as you approach, this post must be at the right rear corner. See **Fig 2a**.
- This manual will show the toprail/mainside being on the left side. See **Fig 3**.
5. With both mainside legs on the chalk lines, lay both legs down toward the inside as shown in **Fig. 4**.
6. Lay toprail on 2 x 4 blocks in front of mainside legs as shown in **Fig. 5**. Align holes on toprail plate with holes on top of mainside leg as shown in **Fig. 6**.
7. Bolt the toprail to the mainside legs using the 1/2 x 2" NC bolts, washers, lock washers, and nuts as shown in **Fig. 7**. These were used in shipping.

NOTE: The set of holes nearest the safety rod hole will not take a flat washer.

8. Raise toprail/leg assembly by pressing and walking the unit into the upright position. Make sure the safety rod holes referred to in **Fig. 7** are still aligned. Make sure both legs are still on the chalk lines.

9. Read the anchoring tip sheet before anchoring. Using the 3/4 carbide bit, drill through the 4 holes in the base plate to a minimum depth of 4-1/2". As soon as you complete drilling a hole, set and drive an anchor bolt into the drilled hole. **DO NOT TIGHTEN ANCHOR BOLTS YET !!**

10. After drilling and setting all 4 anchors in the first post only, plumb the post so that it is perpendicular. Use the level to check the post from side to side, and front to back. You should also check distance measurements from top of one leg to the top of the other leg, and from bottom to bottom. Adjust legs to within 1/8". Use 1/2" flat washers left from packing for shims. Keep shims as close to anchors as possible. Now you may tighten the anchor bolts on first leg only. **Do not use an impact wrench.** Recheck for plumbness and adjust if necessary.

11. After anchoring the first mainside leg, align the other mainside leg in the chalk line. The leg may vary from the chalk line slightly. It is most important that the legs be perpendicular and parallel with the other leg. Check measurements at leg tops and bottoms again. Drill, set, and anchor the other mainside leg. Level and plumb leg as before, then tighten anchors on 2nd leg.

DO NOT DRILL OR ANCHOR OFFSIDE LEGS YET.

12. Set crossrails on 2 x 4 blocks in front of mainside legs, with the machined crossrail connector towards the mainside leg as shown in **Fig. 8**.

13. Use a fish tape to pull the crossrail chain through the crossrail tube. The chain runs under the roller on the offside and over the roller on the mainside. Repeat with the other crossrail. Feed the fish tape through the crossrail starting from the mainside by going over the mainside roller and through the crossrail tube, then under the offside roller and straight up. **See Fig. 8.**

14. Position both crossrails in front of a mainside leg, with the machined connector towards the mainside leg. Using the Master Link provided, connect the crossrail chain to the chain anchor welded to the base plate of the mainside leg. **See Fig. 9.**

******* IMPORTANT *******

THE MASTER LINK MUST HAVE THE CENTER LINK, AND IT MUST BE IN A VERTICAL POSITION. IT CAN NOT BE COCKED TOWARDS THE FRONT OF THE CHAIN ANCHOR. SEE FIG. 10.

15. Starting with the safety latch ear towards the mainside legs, place a 2 x 4 block under the latch as shown in **Fig. 11.**

16. Take a safety rod and remove one of the two nuts. Turn down the remaining nut to the bottom of the threads. Remove packing dowel pin from the crossrail safety latch. Insert safety rod (where packing dowel was removed) into top of crossrail safety latch.

17. Each safety rod corners with 2 nuts on one end. Remove the top nut, turn the other nut down to bottom of threads. Guide the free threaded end of safety rod into the rear hole at the top of the mainside leg. Tighten the nut just removed until the safety rod is flush with the top of the nut. Tighten the bottom nut against the leg top. Remove the 2 x 4 block. Repeat steps 15, 16 and 17 on the other mainside leg and crossrail.

18. Position each offside leg 6" from the end of each crossrail, but do not drill or anchor. Place 2 x 4 blocks under each safety latch. Repeat steps 16 and 17 for the offside legs. **DO NOT ANCHOR OFFSIDE LEGS YET.**

19. Assemble threaded chain connector to free end of chain. Run threaded chain connector into the inside hole at top of offside leg. Run 1" nut all the way down until connector is into the nylon. Repeat on other crossrail. **See Fig. 11.**

20. Stand up cylinder reset on toprail. Remove the fitting or plug from rear of the cylinder as shown in **Fig. 12.** Extend cylinder rod by either pulling on rod or by applying air to cylinder port where fitting or plug was removed. Make sure long chain is not twisted inside toprail tube. Attach loose end of

chain to each crossrail connector using 5/16 x 3 1/2" Grade 8 bolt and nuts. **Do not substitute this bolt!!!!** Repeat on other crossrail. Replace fitting on cylinder.

21. Attach the power unit at its location on the mainside leg with supplied hardware.

22. Before connecting the hydraulic hoses from the power unit to the cylinder you must first install two 90 deg. fittings (2501-06-06) on the cylinder and two 90 deg. fittings with o-rings (6801-LL-06-06) on the power unit. Now the pressure and return hoses can be attached. The 108" pressure hose (ALIF-412-029) goes from the fitting on the cylinder next to the rod to the fitting of the power unit on the side of the handle (pressure port). The 48" return hose (ALIF-412-030) goes from the fitting of the cylinder next to the power unit to the fitting of the power unit on the opposite side of the handle (return port).

23. Have electricity hooked up to the power unit -220 single phase. We recommend a 30 amp breaker and a 30 amp twist lock plug be installed near the power unit.

24. Remove breather cap from power unit. Place a funnel into hold. Fill reservoir with 11 qts of non-detergent 10 wt. hydraulic fluid. Install breather cap.

OFFSIDE LEGS ARE NOT ANCHORED YET.

25. Position tracks on the crossrails. Cycle the lift up about 12". Place a level on the crossrail and level the crossrail by adjusting the nut on the crossrail connector.

26. After leveling crossrails, adjust and plumb the offside legs so that the crossrail chains in the offside legs hang straight. Use a level. Cycle the lift all the way up and down making sure that each corner is running freely. The offside legs may vary from the chalk line slightly. It is more important that the legs be square and plumb, and that the lift moves up and down freely.

27. Raise the lift to the top of its travel. Check the positioning of the crossrails in the legs as the lift is raised. The single point toprail safety latch

will move across the rack at the bottom of the toprail. At the top of the lift's travel, pull down the toprail safety latch banjo until the Reset locks it open. Adjust and plumb crossrails and legs as necessary. When you are positive the lift is moving freely, you may finally drill and install the anchor bolts in the offside legs.

28. Position/install position and install stops on opposite end of vehicle approach end. Drop ramps on slotted hole of the approach end.

29. Cycle the lift it's maximum height and back to the ground at least 3 full cycles without any load to remove air from the hydraulic system.

SAFETY AND OPERATING PROCEDURES

Before attempting to operate this lift, be familiar with it's basic operational and safety procedures.

1. Prior to lifting a vehicle, walk around the lift and check for any objects that might interfere with the operation of the lift and it's safety latches such as: tools, air hoses, shop equipment, etc.
2. Slowly drive the vehicle fully onto the tracks. Have someone outside the vehicle guide the vehicle down the tracks.
3. After vehicle is secured, begin raising lift by pressing the UP button on the power unit. **UNDER NO CIRCUMSTANCES SHOULD ANY PERSONNEL RIDE THE LIFT UP OR DOWN.**
4. Pay close attention to the locking mechanism as the unit rises. The operator should be able to listen for the safety locks acting against the latch rack as the unit goes up.
5. To back vehicle off the lift: Slowly drive vehicle fully off the lift.

PERIODIC MAINTENANCE

1. Anchor bolts: During the first week of use, check and tighten anchors daily. **Do not use an impact wrench.** After first week, check anchors once a month.
2. Concrete: Check concrete for stress cracks daily for the first two weeks of use. Thereafter, check monthly.
3. Check all bolts and nuts monthly.
4. If your lift will raise all the way to the top, your lift has enough oil. Hydraulic oil should be changed and the suction filter cleaned once a year. If the lift environment is outside or dusty, change hydraulic oil and clean suction filter every six months.
5. Chain: Check chain every 3 months for any sign of rust or wear, especially if lift is located outside. Lubricate with a chain lube spray.
6. Bearings: The bearings on your lift are sealed roller bearings, which do not require any additional lubrication. Check bearings every 3 months for excessive wear between the chain and roller.

PARTS & SHIPPING LIST

PART NUMBER	DESCRIPTION	QTY.	
2501-06-06	3/8MNPT x 3/8MJIC 90 Deg. Adapter	2	HK
5304ZZ	DS Bearings	4	HK
6801-LL-06-06	0.375M x 0.375F 90 Deg. NPT Adapter w/O-ring	2	HK
7130K55	11" Black Ties	6	HK
80050	BL634 Master Link	4	HK
90126A033	1/2 SAE Flat Washer	6	HK
90473A036	3/4-10UNC Hex Nut Grd. 2	4	HK
90473A223	1/2-13UNC Hex Nut Grd. 2	20	HK
90640A130	5/16-18UNC Hex Nylon Lock Nut Grd. 2	4	HK
91102A033	1/2 Lock Washer	4	HK
91102A036	3/4 Lock Washer	4	HK
91247A583	5/16-18UNC x 1 HHCS Grd. 5	4	HK
91578A501	3/4-10UNC x 5 1/2 Wedge Anchor Set	16	HK
92865A718	1/2-13UNC x 1 3/4 Lg. (Full Thrd) HHCS Grd. 5	4	HK
92865A841	3/4-10UNC x 1 3/4 Lg. (Full Thrd) HHCS Grd. 5	4	HK
95462A538	3/4-10UNC Hex Nut Grd. 5	8	HK
95462A555	1-14UNF Hex Nut Grd. 5	4	HK
95473A030	5/16-18UNC Hex Nut Grd. 2	4	HK
98338A140	3/32 x 1 Cotter Pin	8	HK
98410A128	3/4 " Retainer Ring	6	HK
AH-1008	Power Unit	1	PKG
ALGF-412-031-XX	Ramp Weldm't.	2	PKG
ALGF-412-034	Ramp Pivot Pin	2	PKG
ALIF-412-001-XX	Front Stop	2	PKG
ALIF-412-003-XX	Track Weldm't.	2	PKG
ALIF-412-029	0.375FJICS x 0.375FJICS Hose x 108"	1	PKG
ALIF-412-030	0.375FJICS x 0.375FJICS Hose x 48"	1	PKG
ALIG-412-099	Sq. U-Bolts	8	PKG
GL-9-056	1/16 x 1 x 2 3/4 Steel Shim	16	PKG
GL-9-112	1/4 x 1 x 2 3/4 Steel Shim	12	PKG
GL-12-002-XX	Mainside Leg Weldm't.	1	PKG
GL-12-003-XX	Mainside Leg Weldm't. with P/U Mount	1	PKG
GL-12-004-XX	Offside Leg Weldm't.	2	PKG
GL-12-049	Offside Leg Chain Connector	2	PKG
GL-12-052	Safety Latch Rod	4	PKG

GL-12-103	Top Rail Assy.	1	PKG
AA-3515001	3.50 Dia. 72" Stroke Hyd. Cylinder	1	
90126A036	¾ SAE Flat Washer	2	
94945A235	¾-16UNF Thin Nylon Lock Nut	3	
98410A133	1.000 Dia. Retainer Ring	1	
98410A249	1.375 Dia. Retainer Ring	5	
98381A593	0.313 Dia. x 2.5 Lg. Dowel Pin	2	
GL-12-005-XX	Top Rail Weldm't.	1	
GL-12-030-XX	Safety Latch Banjo	2	
GL-12-046-XX	Top Rail Reset	1	
GL-12-048	Latch Pin	1	
GL-12-050	Cylinder Chain Connector	1	
GL-12-053-XX	5.5 Dia. Top Rail Wheel	2	
GL-12-056	4.0 Dia. Pulley	3	
GL-12-095	Std. BL646, 129 Pitch Male Ends, Short Top Rail Chain	1	
GL-12-096	Std. BL646, 347 Pitch Male Ends, Long Top Rail Chain	1	
GL-12-100	1 Dia. Cylinder Pin	1	
GL-12-101	1 3/8 Dia. Pulley Pin	3	
GL-12-104	Cross Rail Assy.	2	PKG
90108A036	¾ USS Flat Washer	8	
97801A104	1/8 x 2 Lg. Nail	8	
98410A128	0.750 Dia. Retainer Ring	10	
ALIF-412-012	Packing Pin	4	
C1100-112-4500M	1.10 O.D. x 4 ½" Safety Latch Spring	4	
GL-12-006-XX	Cross Rail Weldm't.	2	
GL-12-055	2.25 Dia. Pulley	4	
GL-12-057	Cross Rail Chain Connector	2	
GL-12-078	Safety Stop Plate	4	
GL-12-089-XX	Safety Latch	4	
GL-12-098	Safety Latch / Bearing Pin	2	
GL-12-099	Safety Latch Pin	6	
GL-12-094	BL634, 271 Pitch Male Ends, Cross Rail Chain	2	PKG
91259A587	0.313 Dia. 1.50 Lg. Shoulder Bolt	2	HK
90640A129	¼-20UNC Nylon Lock Nut	2	HK

*** Note: All hardware unless specified is grade 2. All hardware is zinc coated unless specified. Parts with PKG at the end are packed on the lift and parts with HK at the end are packaged in a box and put on the lift.

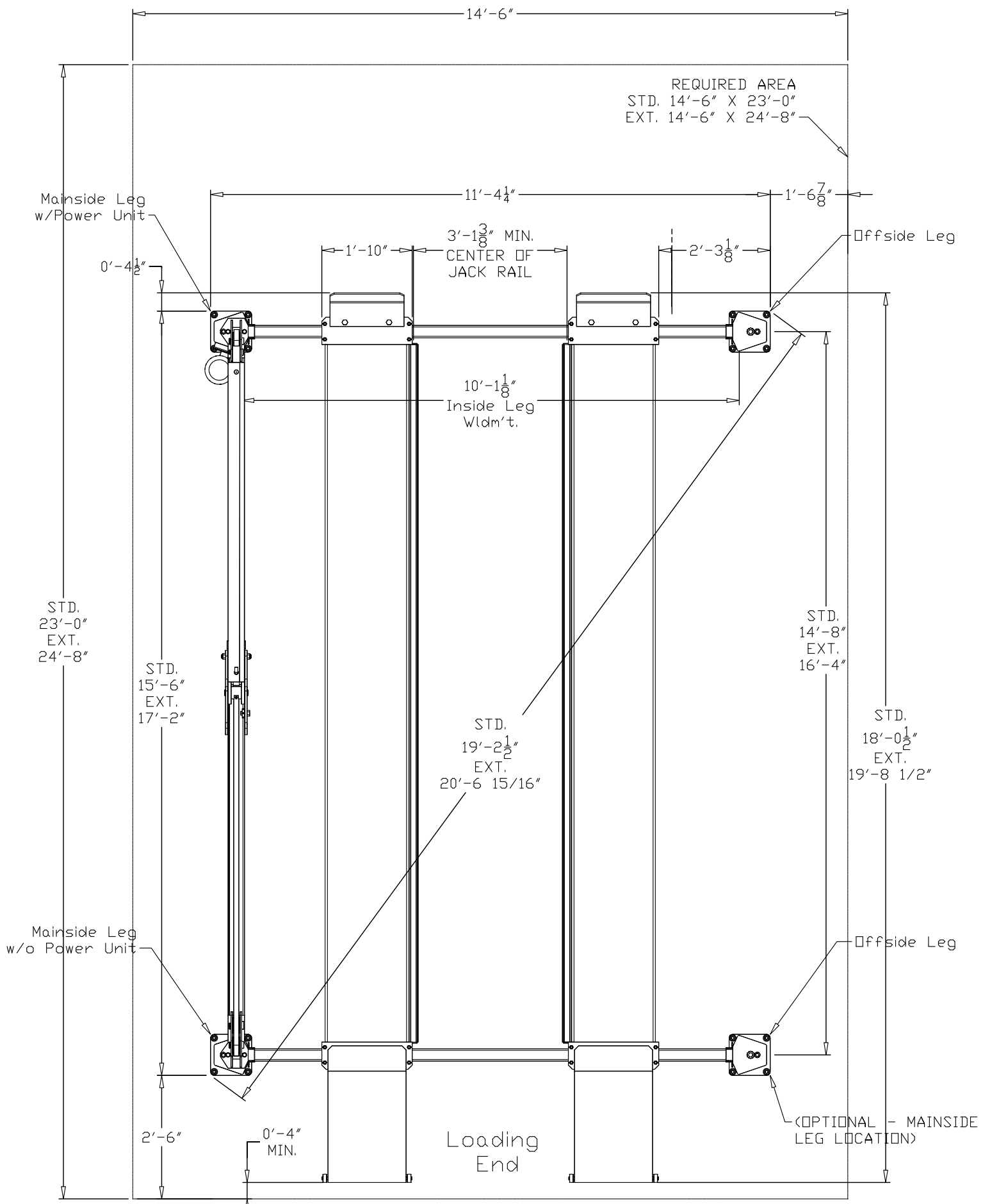
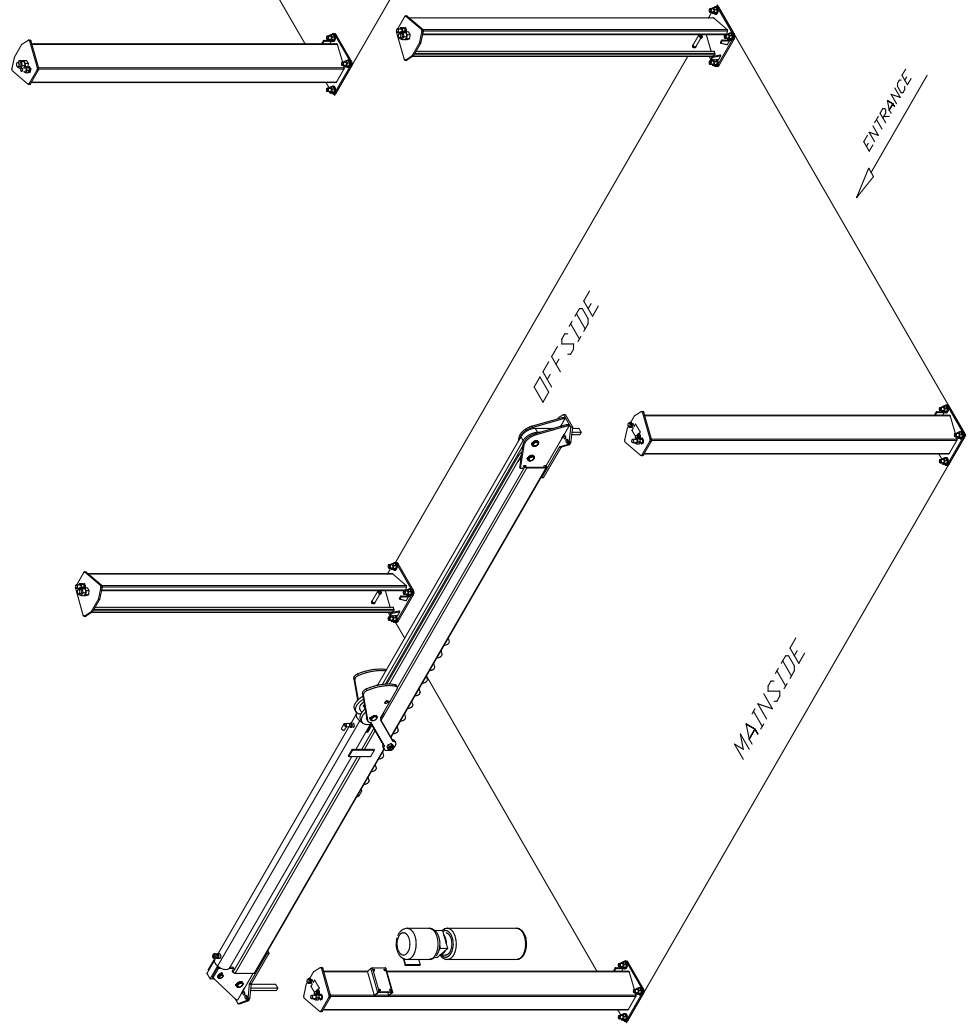
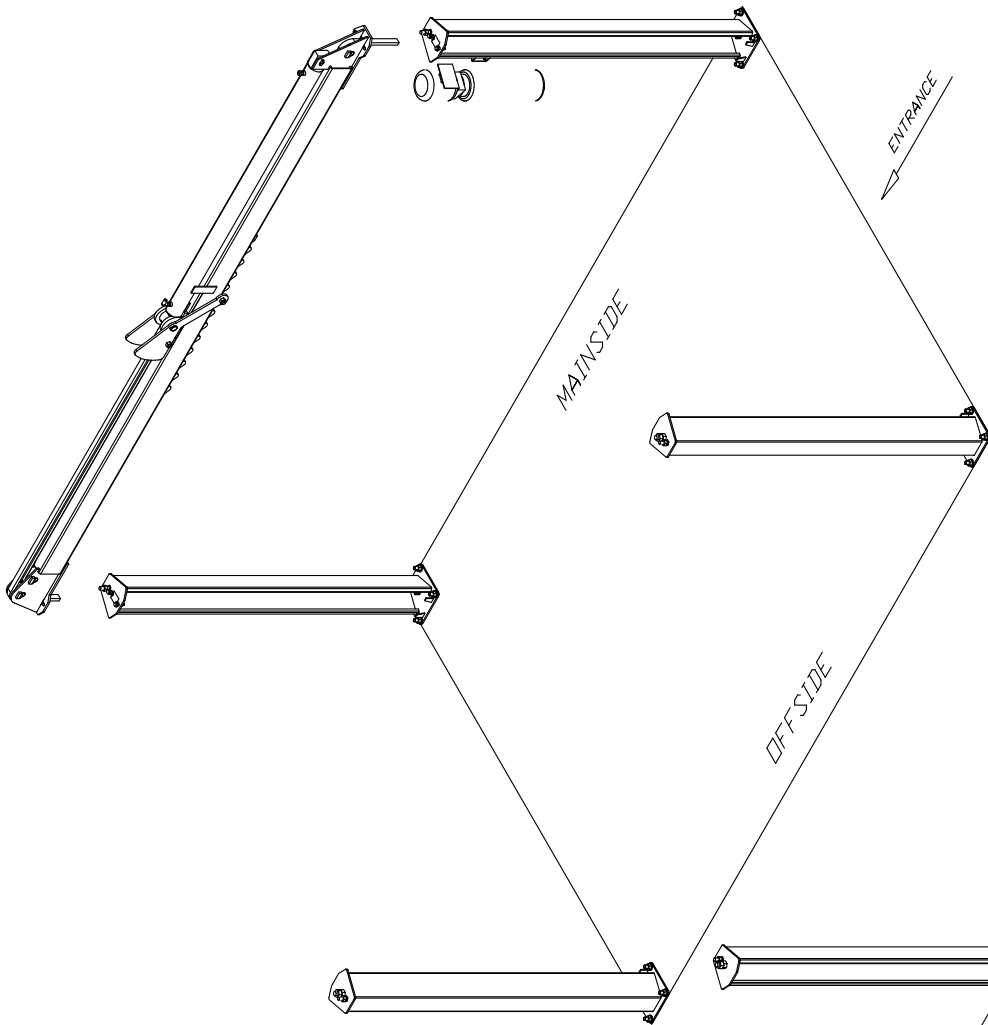

FIG #1 WFP12R & WFP12R-E LAYOUT & INSTALLATION SPECIFICATION



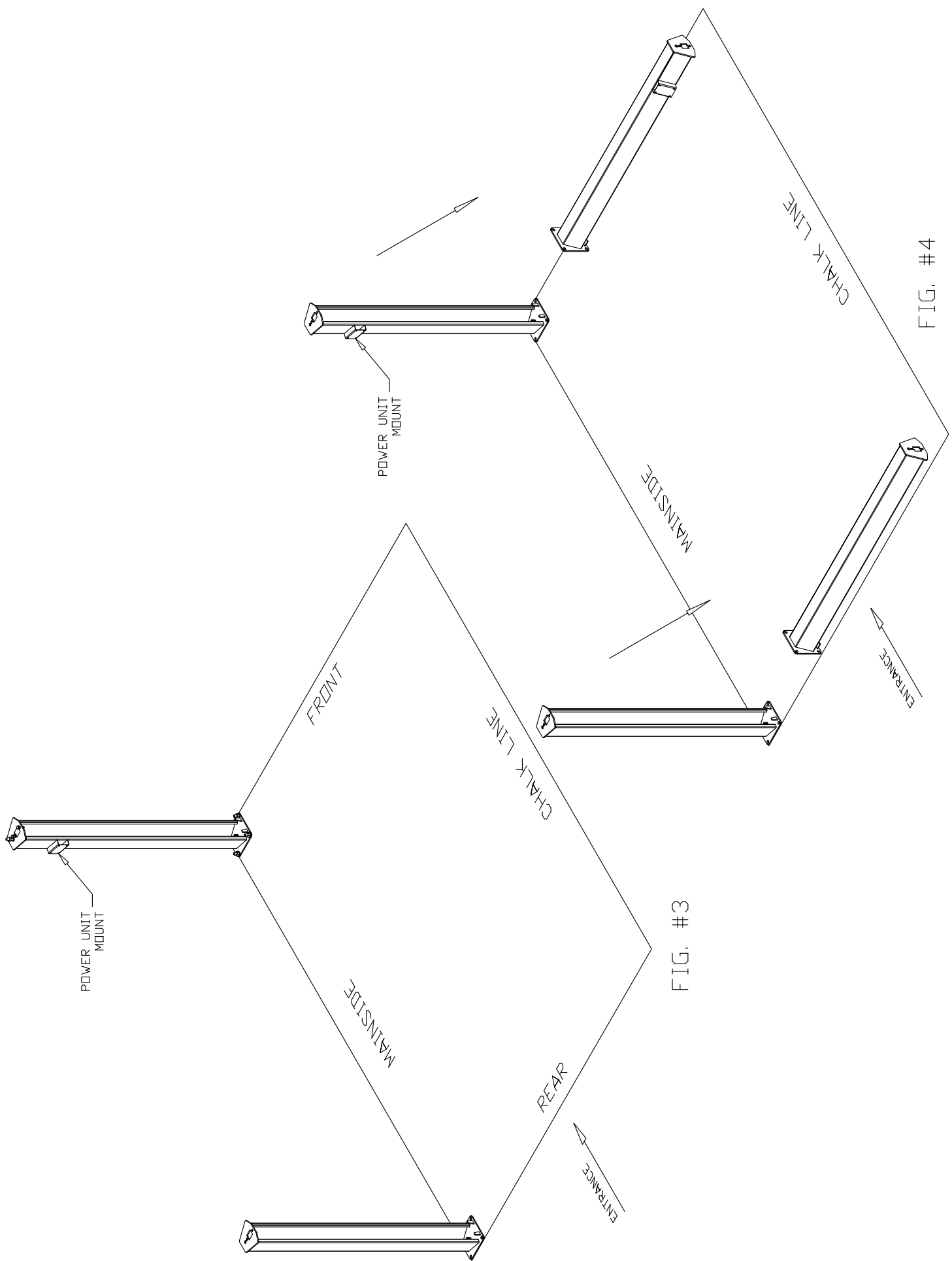

FIG. #4

FIG. #3

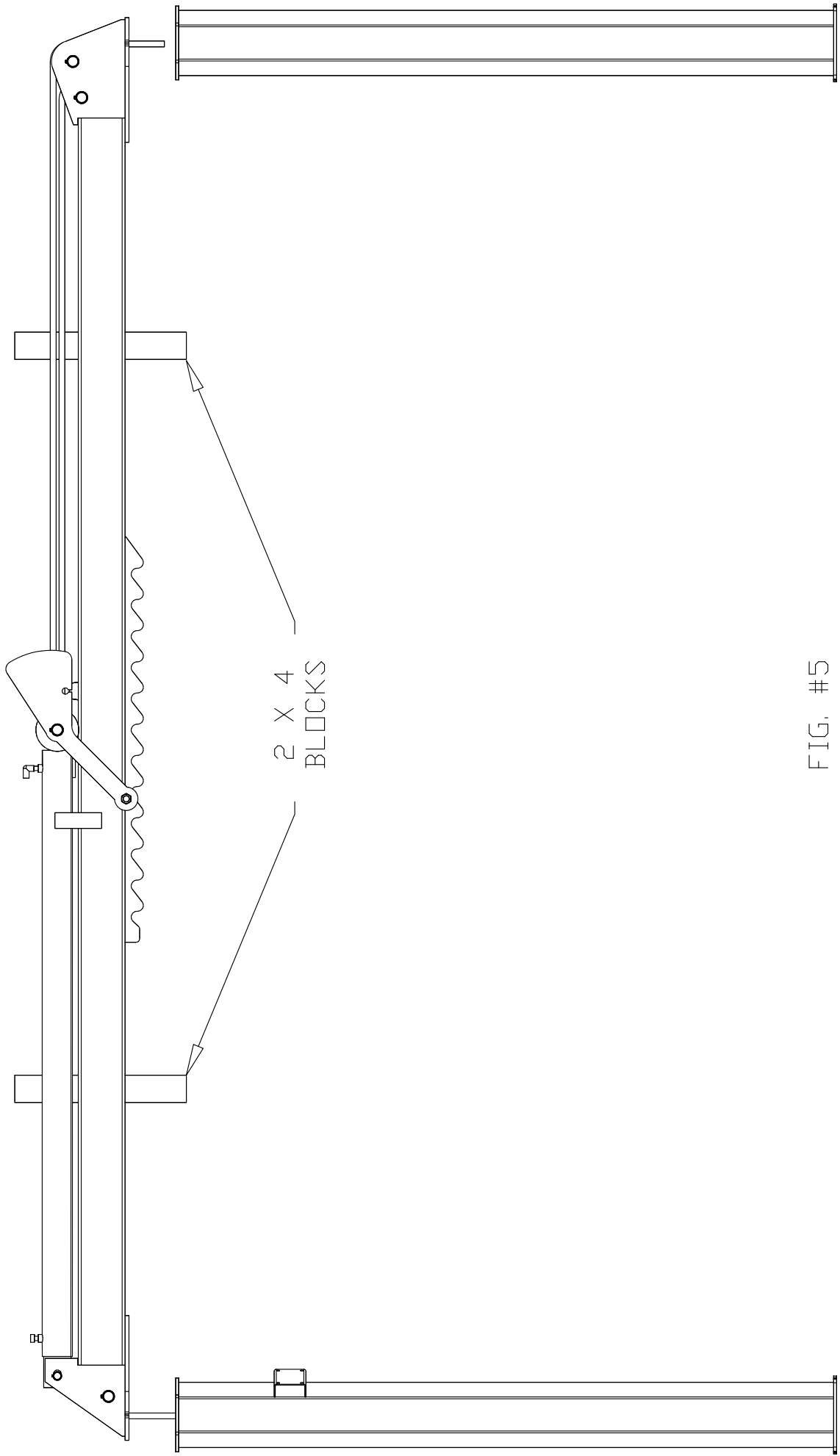

FIG. #5

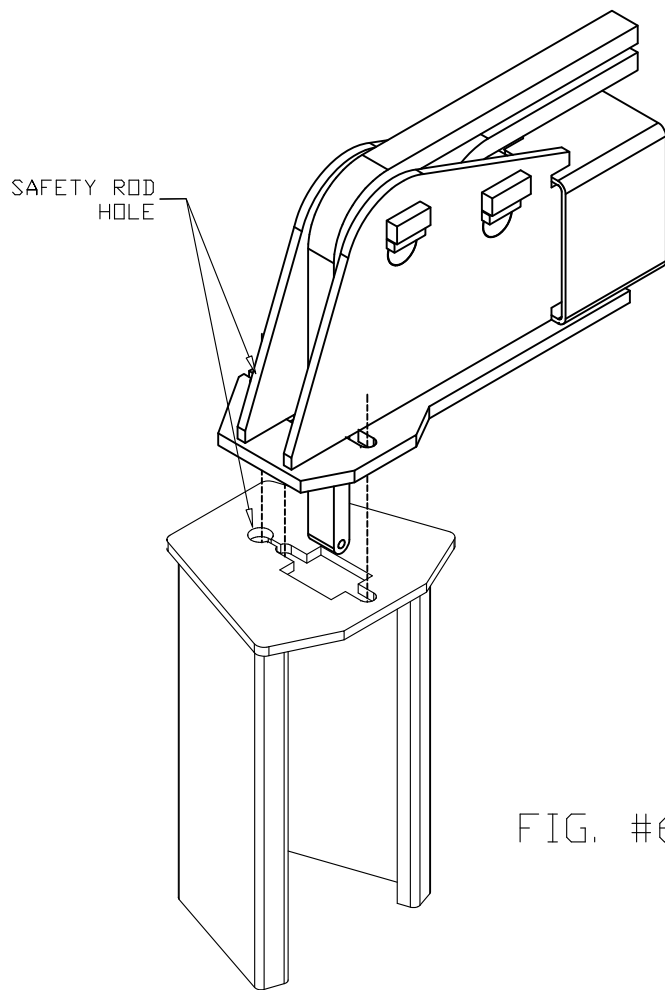
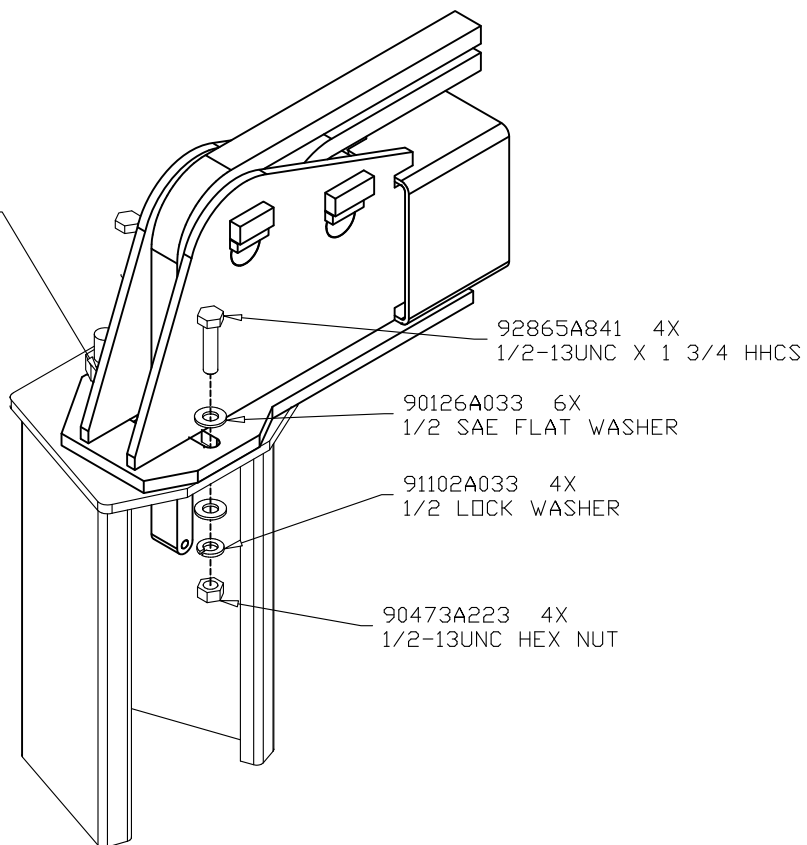

FIG. #6

** NO FLAT
WASHER ON TOP,
(SAFETY ROD SIDE)



92865A841 4X
1/2-13UNC X 1 3/4 HHCS

90126A033 6X
1/2 SAE FLAT WASHER

91102A033 4X
1/2 LOCK WASHER

90473A223 4X
1/2-13UNC HEX NUT

FIG. #7

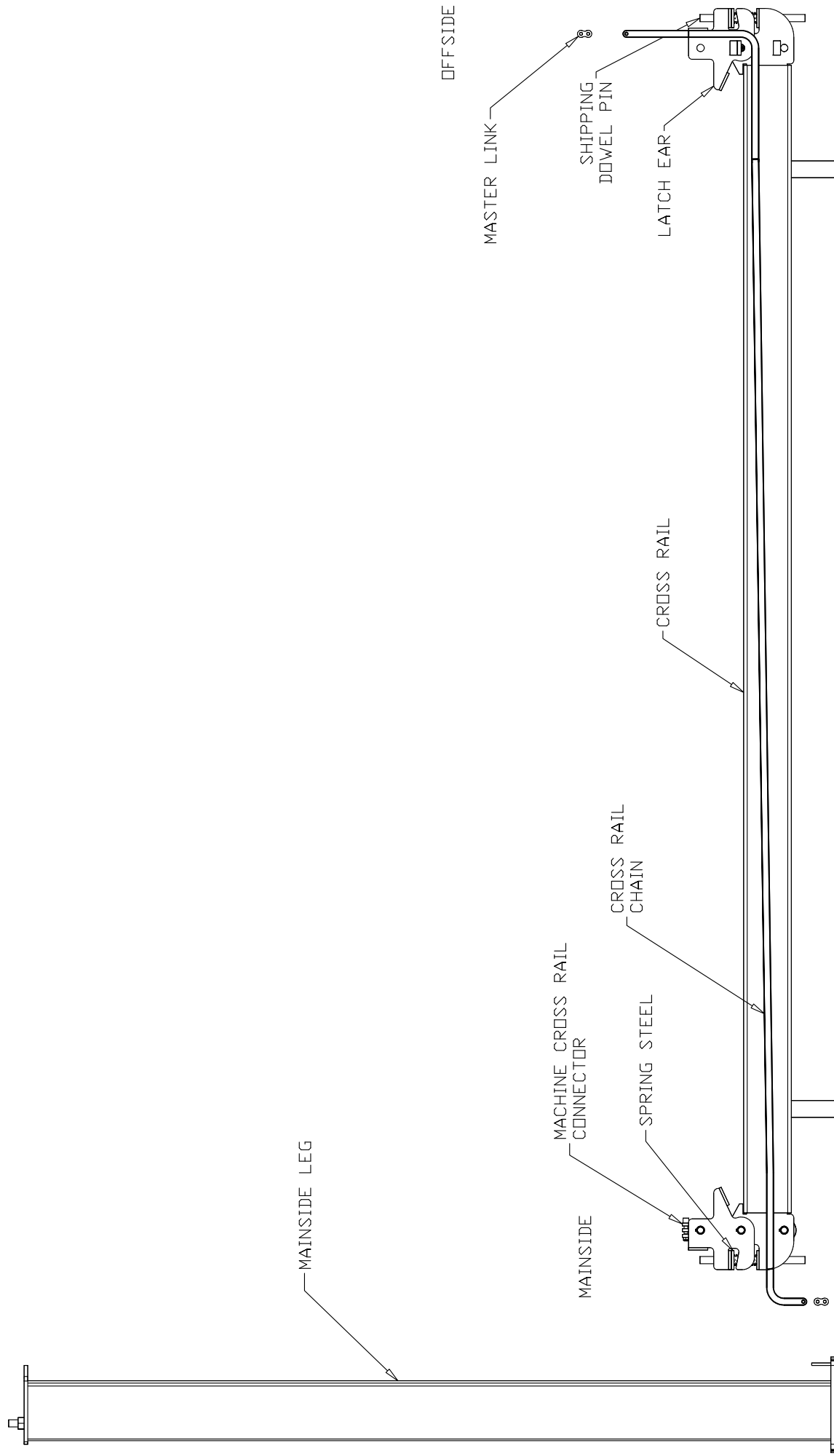

FIG. #8

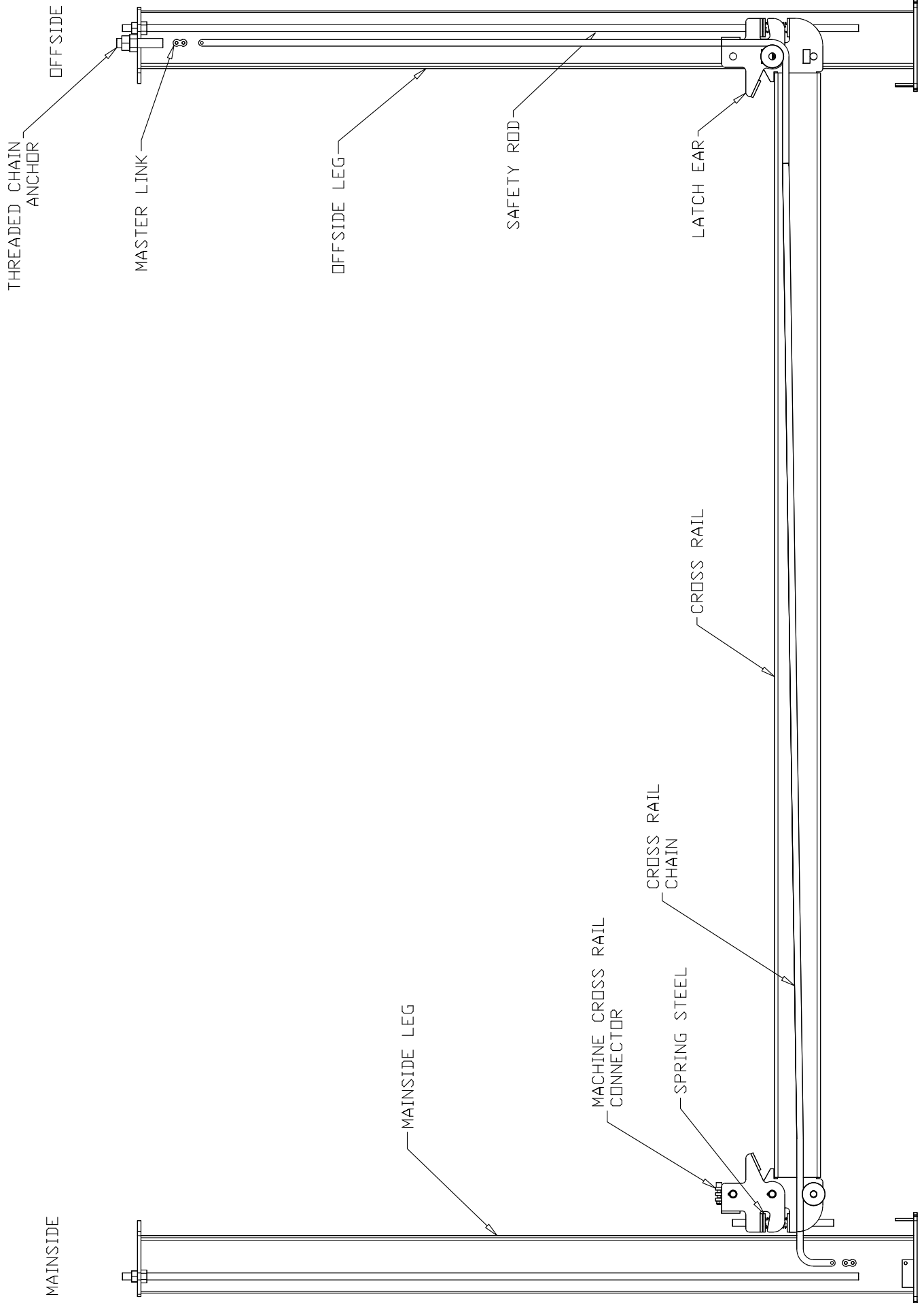

FIG. #9

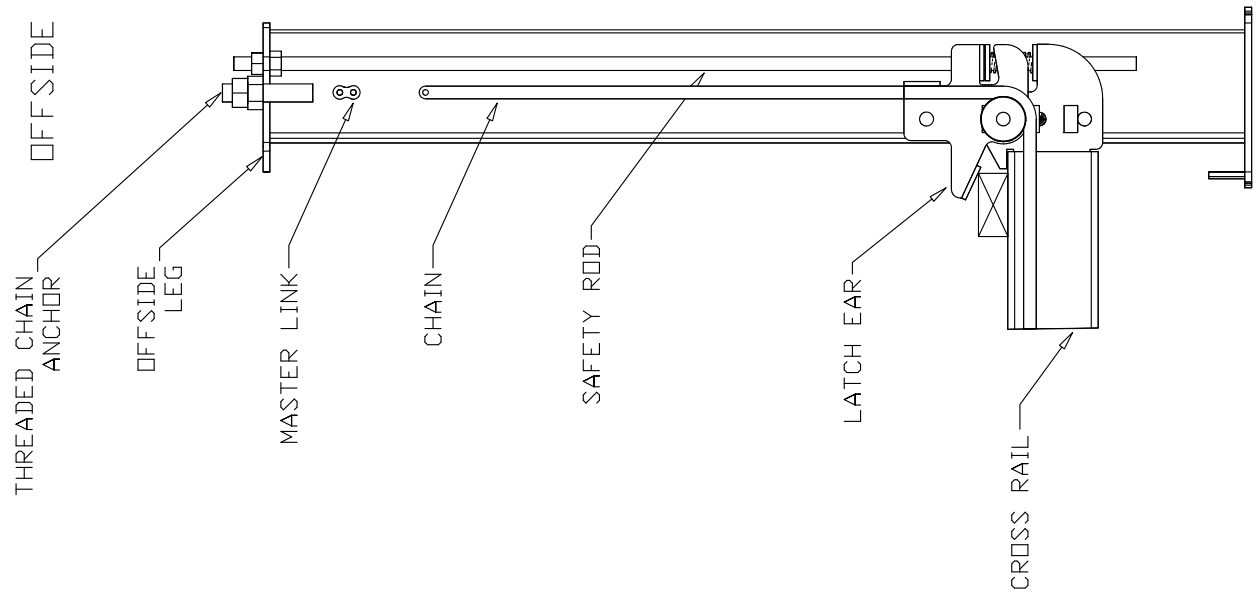

FIG. #11

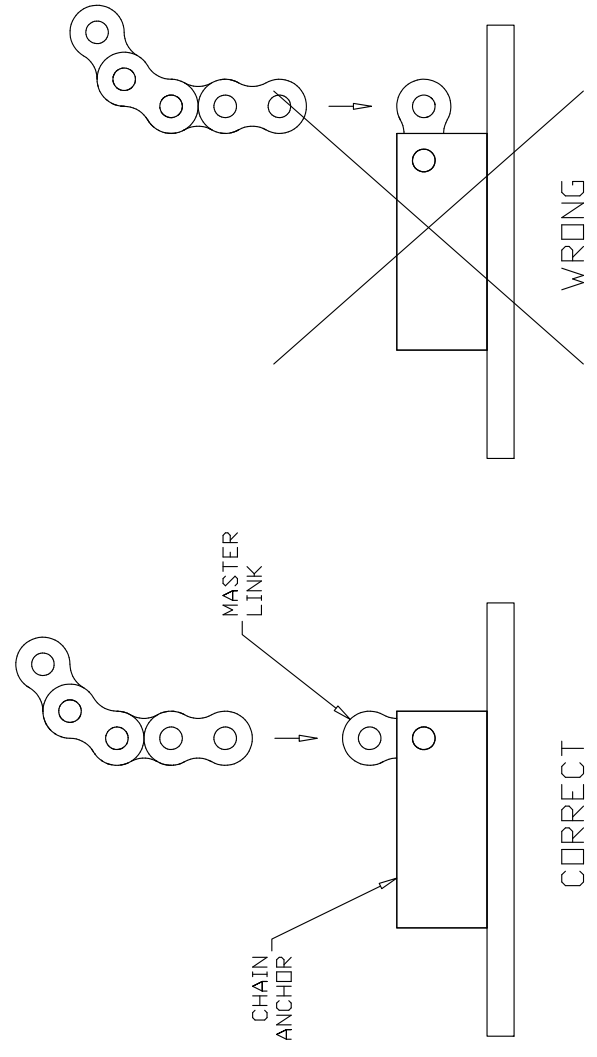

FIG. #10

2501-06-06 2X
3/8 MNPT X 3/8 MJIC 90° ADAPTER

STAND
LATCH UP

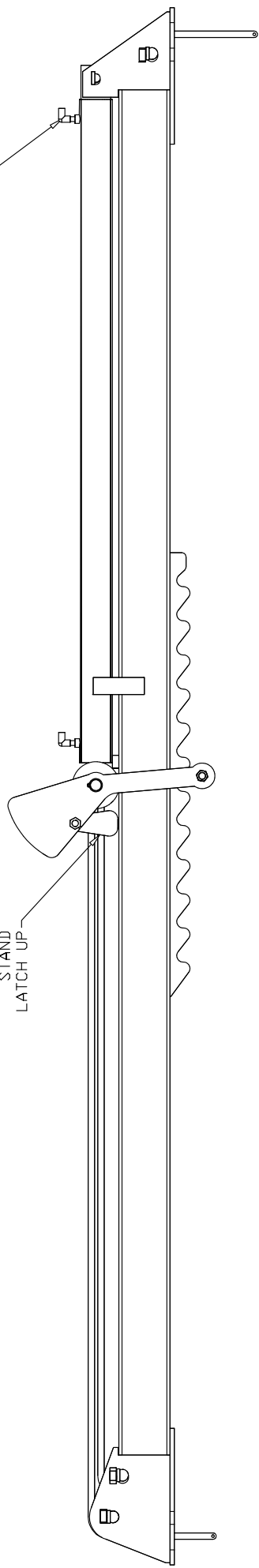
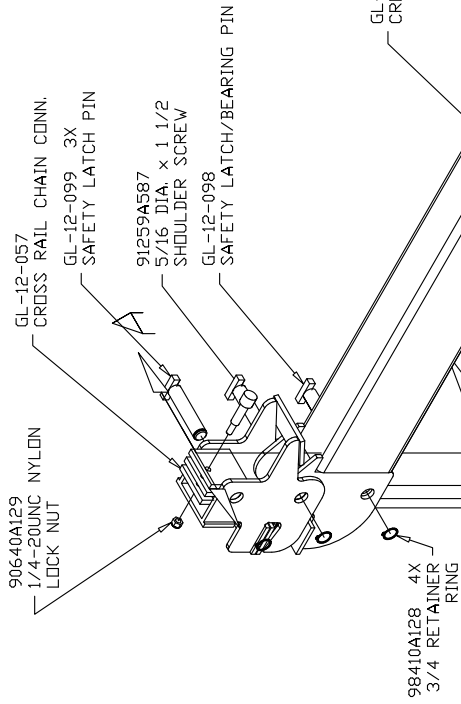
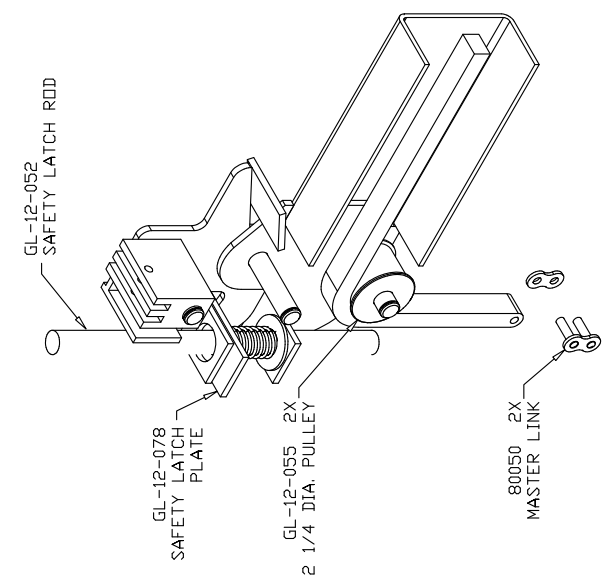

FIG. #12



MAINSIDE LEG SIDE



MAINSIDE LEG SIDE
SECT. VIEW A-A

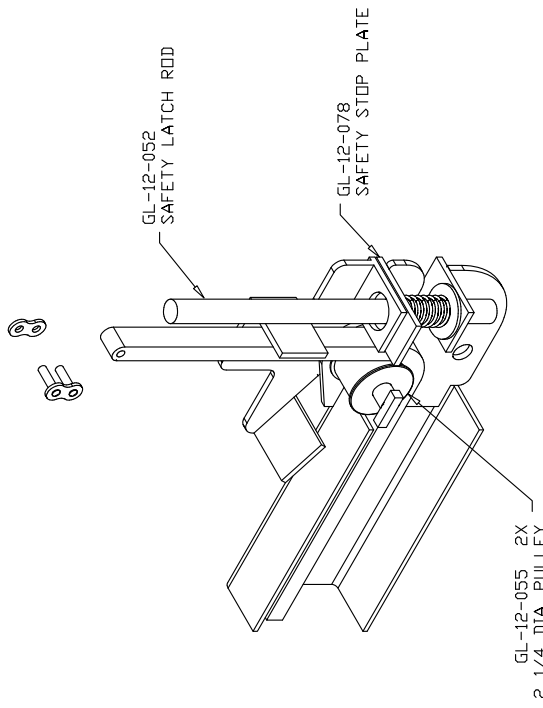

OFFSIDE LEG SIDE
SECT. VIEW B-B

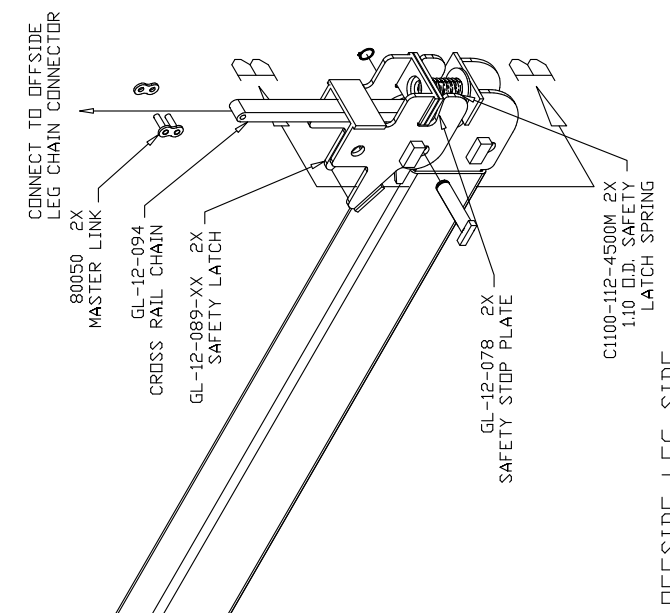

OFFSIDE LEG SIDE

CROSS RAIL ASSY.

ALIF-412-001-XX
FRONT STOP

92865A841 2X
3/4-10UNC X 1 3/4 HHCS

90473A223 4X
1/2-13UNC HEX NUT

CROSS RAIL TUBE

91102A036 2X
3/4 LOCK WASHER

90473A036 2X
3/4-10UNC HEX NUT

ALIF-412-003-XX
TRACK WELDMT.

98410A128 3X
3/4" RETAINER RING

ALGF-412-031-XX
RAMP WLDWT.

5304ZZ 2X
DS BEARING

CROSS RAIL TUBE

ALGF-412-034
RAMP PIVOT PIN

ALIG-412-099 4X
SQ. U-BOLTS

90473A223 4X
1/2-13UNC HEX NUT

TRACK, RAMP & STOP ASSEMBLY

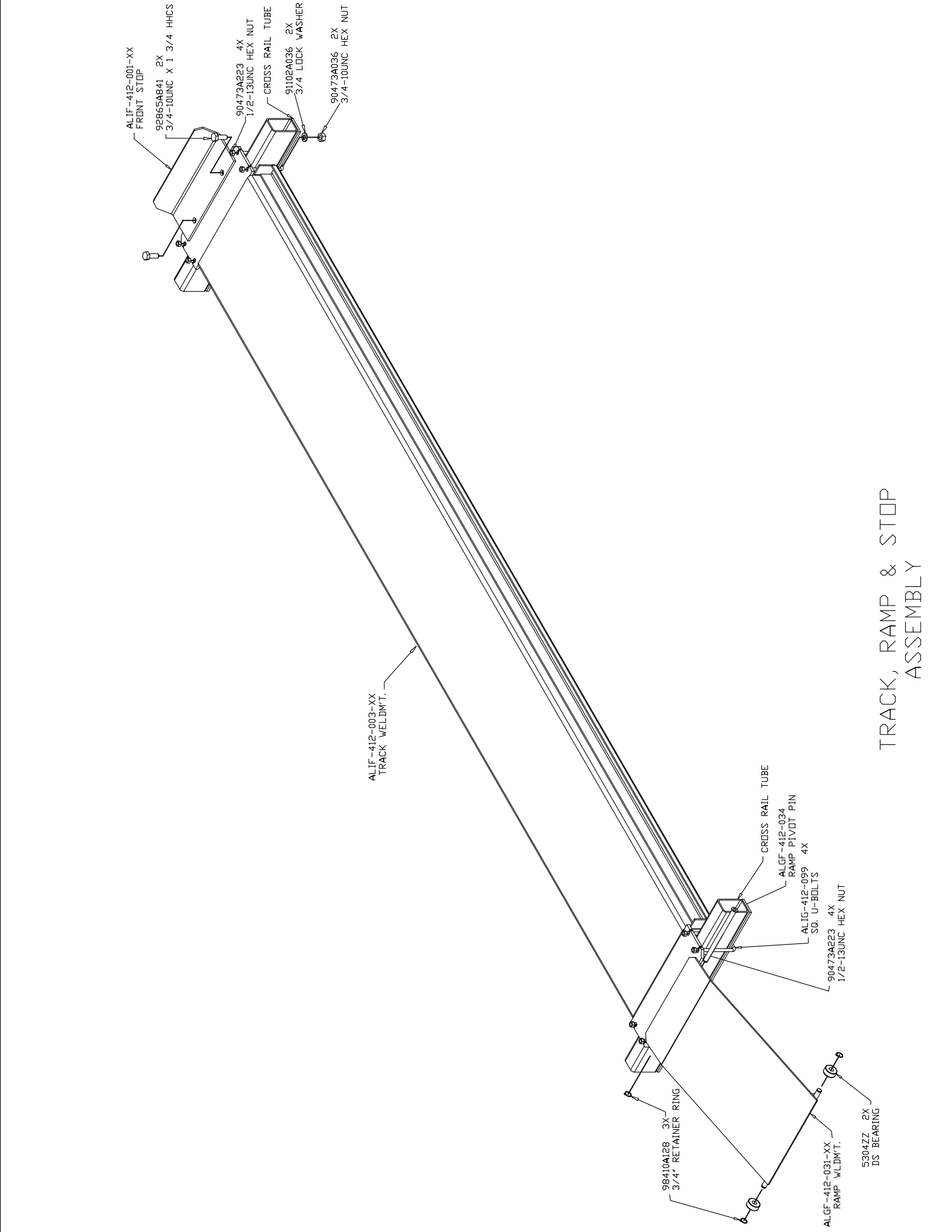

GL-12-049
TREADED CHAIN CONN.
95462A538 2X
3/4-10UNC HEX NUT
90126A038
1 SAE FLAT WASHER
90126A038 2X
1-14UNF HEX NUT

95462A538 2X
3/4-10UNC HEX NUT

GL-12-003-XX 1X
MAINSIDE LEG WELDM'T.
(w/ P/U MOUNT)

GL-12-002-XX 1X
MAINSIDE LEG WELDM'T.
(w/o P/U MOUNT)

GL-12-052
SAFETY LATCH ROD

GL-12-052
SAFETY LATCH ROD

GL-12-004-XX 2X
OFFSIDE LEG WELDM'T.

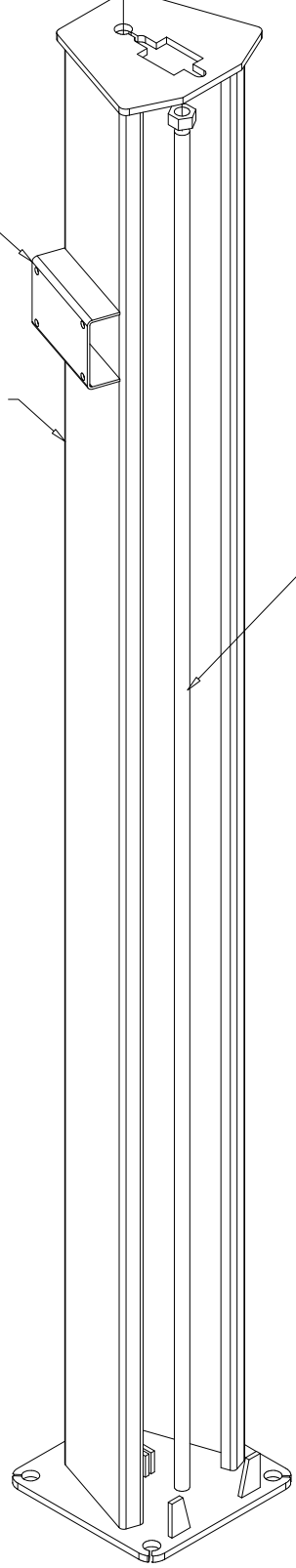
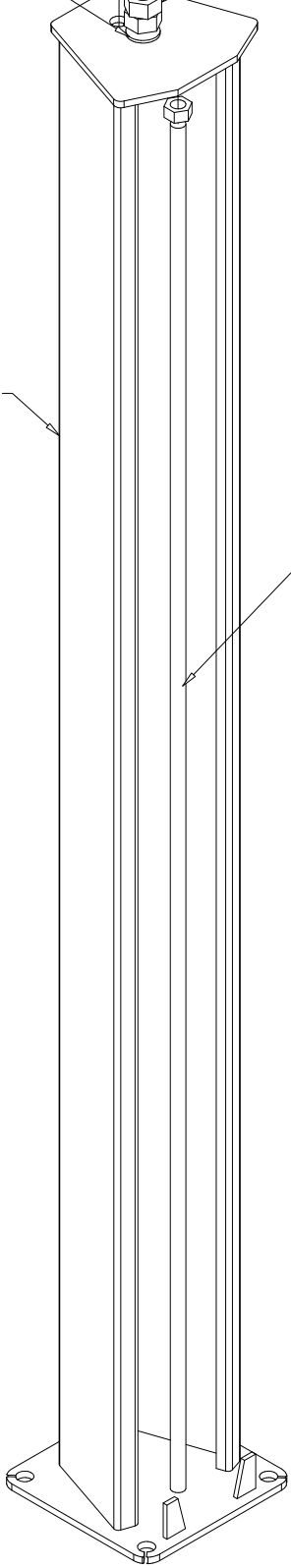

OFFSIDE LEG ASSY.

MAINSIDE LEG ASSY.
w/P/U MOUNT SHOWN

LEG ASSEMBLIES

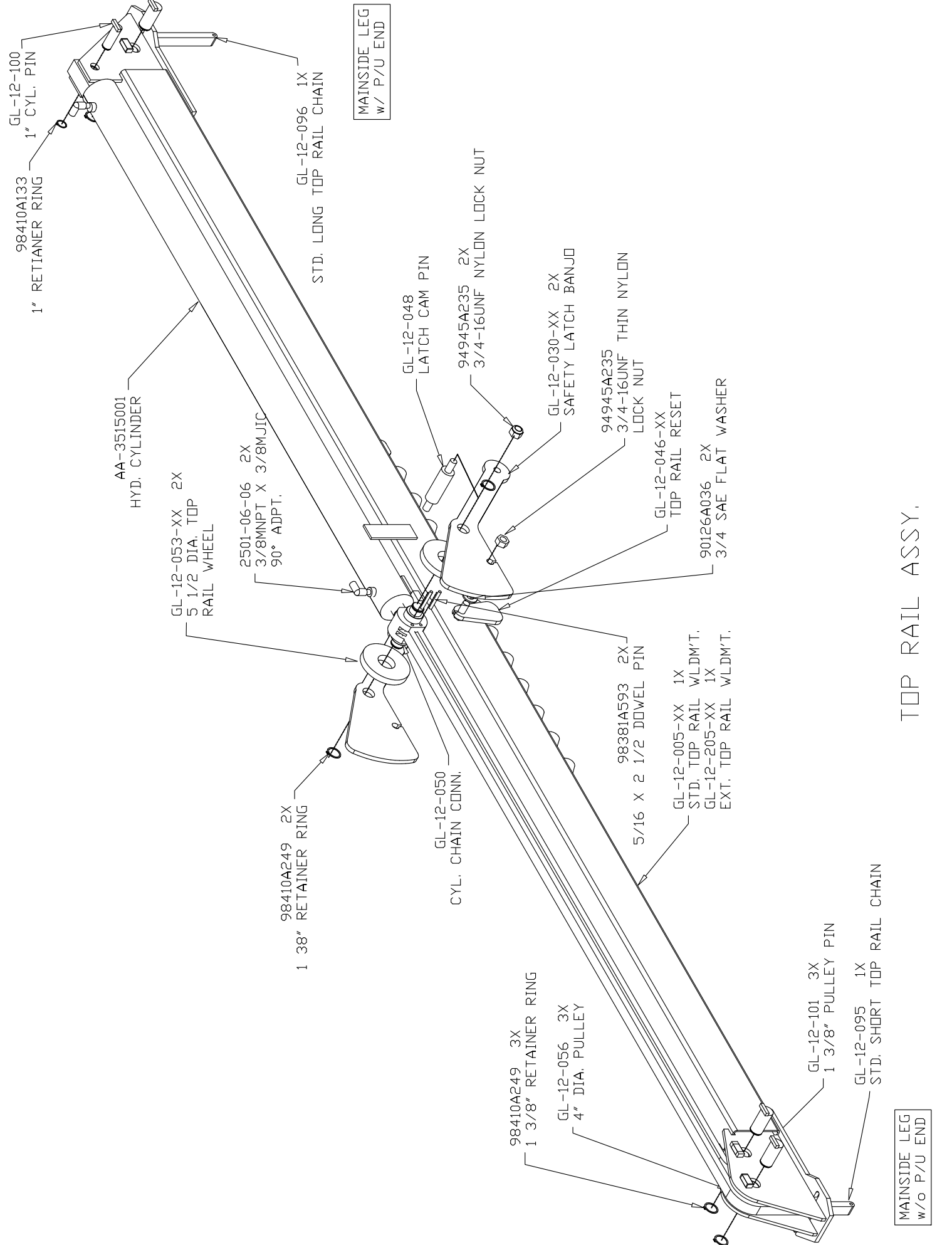

TOP RAIL ASSY.

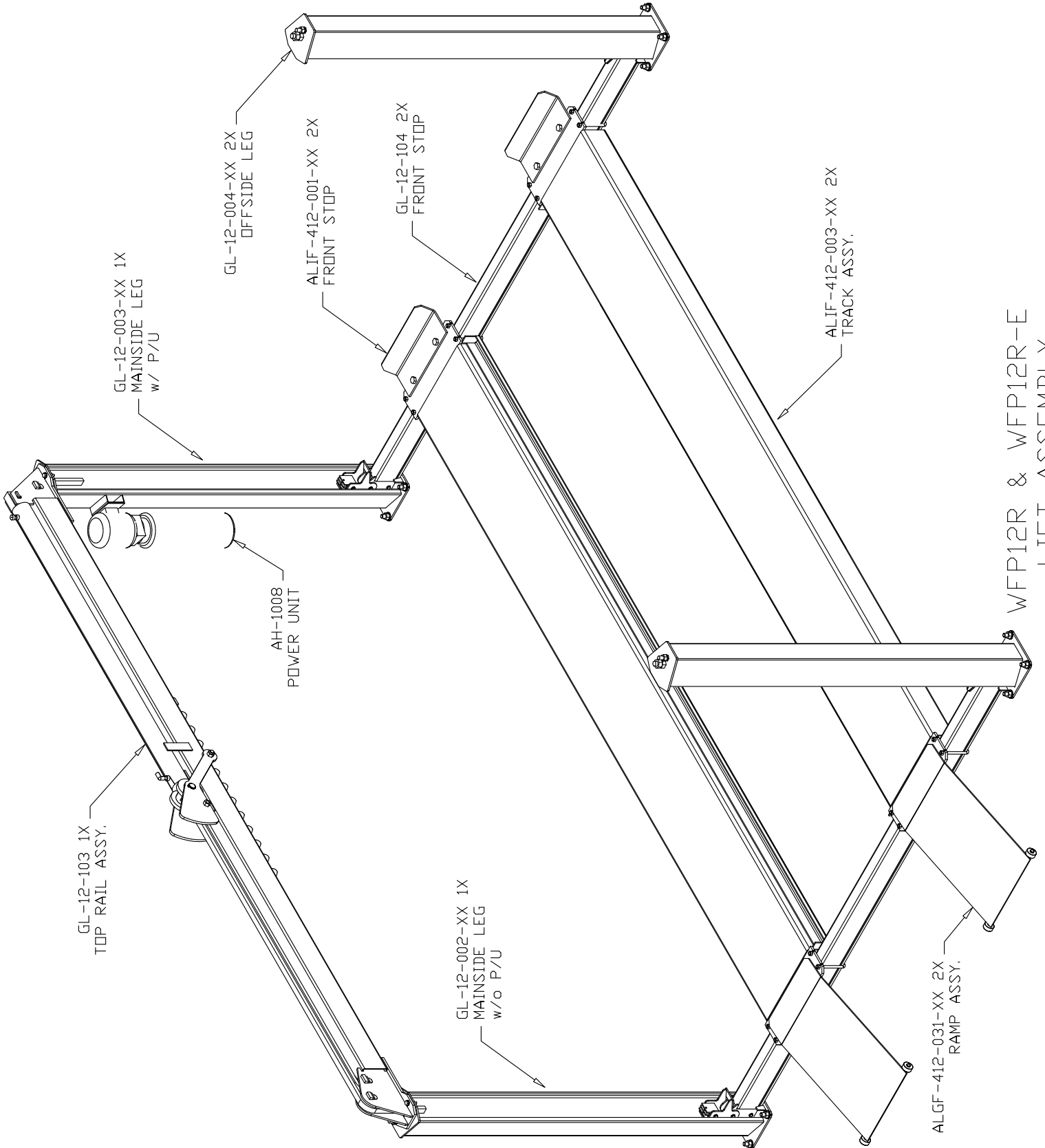

GL-12-103-1X
TOP RAIL ASSY.

GL-12-003-XX 1X
MAINSIDE LEG
w/ P/U

AH-1008
POWER UNIT

GL-12-004-XX 2X
OFFSIDE LEG

ALIF-412-001-XX 2X
FRONT STOP

GL-12-104 2X
FRONT STOP

GL-12-002-XX 1X
MAINSIDE LEG
w/o P/U

ALIF-412-003-XX 2X
TRACK ASSY.

ALGF-412-031-XX 2X
RAMP ASSY.

WFP12R & WFP12R-E
LIFT ASSEMBLY

**ANTI-SWAY KIT FOR
12K FOUR POST LIFTS
P/N: ALIF-412-028**

INSTALLATION INSTRUCTIONS:

1. Insert the nylon Rub Block onto the Sway Guide Weldment. Tap the block on with a hammer. It is very important that the block be fully seated on the fixture.
2. Raise the lift 2 feet.
3. Place the Rub Block end of the Sway Guide up into the corner of the leg.
4. Push the Sway Guide up onto the Cross Rail. Make sure the Sway Guide is in contact with the bottom of the Cross Rail. NOTE: The kit must be installed as shown in FIG. #1 with the bolt on top of the Cross Rail.
5. Once the fixture is fully seated begin securing the Sway Guide with the hardware provide. Make sure the Rub Block is fully seated in the corner of the leg before tightening down.
6. FIG. #2 shows the placement of the Sway Guide on one ends of the Cross Rail.

IMPORTANT:

The Rub Block **MUST BE** securely seated into the corner of the leg for the Sway Guide to work properly. If not, the Cross Rail Latch weldment will hit the bolt.

PARTS LIST

PART NO.	DESCRIPTION	QTY.
ALIF-412-021-XX	Sway Guide Weldm't.	4
ALIF-412-026	Rub Block	4
90126A033	½ Flat Washer	8
90640A133	½-13UNC Nylon Lock Nut	4
91247A730	½-13UNC HHCS x 4 ½ Lg.	4

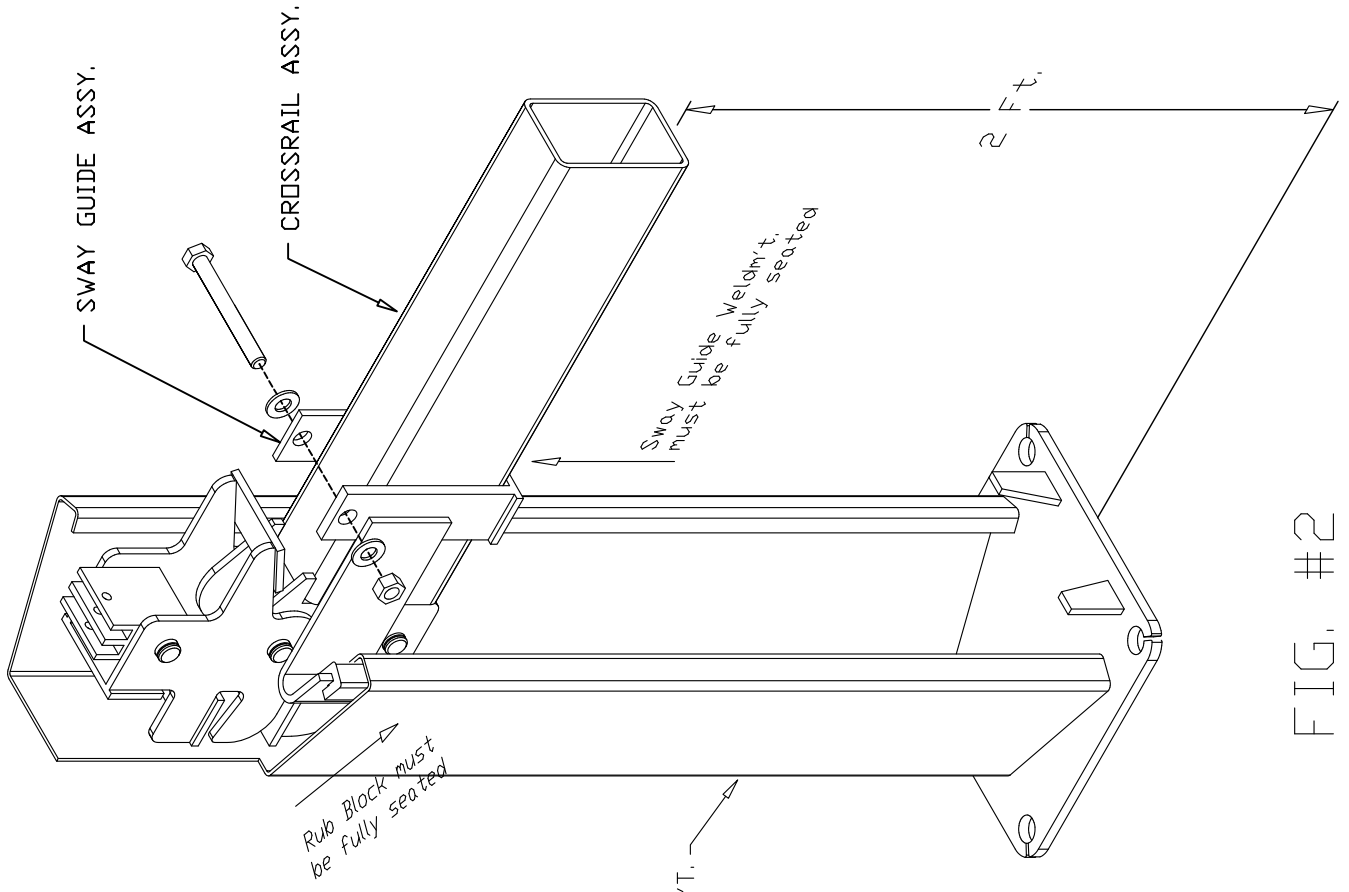

FIG. #2

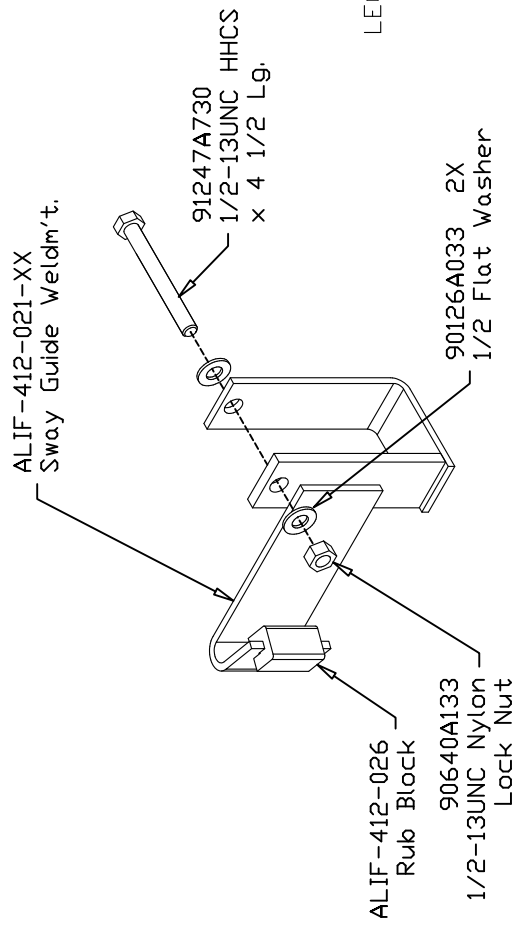

FIG. #1